

VEHICLE HEATERS, ADDITIONAL PARTS, INSTALLATION TIPS AND TECHNICAL DATA



TABLE OF CONTENTS

1	HEATING SYSTEMS	
	HEATING SYSTEMS – AIR OR WATER?	5
	HEATING SYSTEMS: HYDRONIC – WATER HEATERS	6
	HEATING SYSTEMS: AIRTRONIC – AIR HEATERS	7
2	HYDRONIC	
	HYDRONIC: TECHNOLOGY	8–10
	HYDRONIC: DEVICE OVERVIEW	11–15
	HYDRONIC: DEVICE RANGE	16
	HYDRONIC: VEHICLE-SPECIFIC ADDITIONAL PARTS	17
	HYDRONIC: COMPLETE PACKAGES/UNIVERSAL INSTALLATION KITS	18
	HYDRONIC: PARTS RANGE	19–21
	HYDRONIC: CONTROL ELEMENTS	22–23
	HYDRONIC: OPTIONAL ADD-ONS	24–29
3	AIRTRONIC	
	AIRTRONIC: TECHNOLOGY	30
	AIRTRONIC: DEVICE OVERVIEW	31–32
	AIRTRONIC: DEVICE RANGE	33–35
	AIRTRONIC: INSTALLATION PARTS	36–51
	AIRTRONIC: CONTROL ELEMENTS	52–53
	AIRTRONIC: OPTIONAL ADD-ONS	54–55
4	SERVICE	
	SERVICE: DIAGNOSTIC TOOLS	56
	SERVICE: TESTING EQUIPMENT	57
	SERVICE: IPCU	58
	SERVICE: SERVICE/REPLACEMENT DEVICE PROGRAM	59
	SERVICE: ADDITIONAL HEATER REPLACEMENT DEVICES	60
	SERVICE: AIRTRONIC S-DEVICES, COMPACT LC	61
5	THE BENEFITS	
	THE BENEFITS FOR WORKSHOPS	62
	THE BENEFITS FOR END CUSTOMERS	64–65

ACCESSORIES

6	WATER LINES	66 – 74
7	AIR LINES	74 – 83
8	FUEL LINES	84 – 90
9	ELECTRICAL PARTS/TESTING EQUIPMENT	91 – 109
10	EXHAUST AND COMBUSTION-AIR LINES	110 – 117
11	FASTENING PARTS	118 – 127
12	NAME PLATES/INFORMATION SIGNS	128 – 130
13	ADDITIONAL PRODUCTS – CONVECTORS AND INDIVIDUAL DEVICES	131 – 139



- 1
- 2
- 3
- 4
- 5
- 6
- 7
- 8
- 9
- 10
- 11
- 12
- 13

1 | HEATING SYSTEMS – AIR OR WATER?

The basic principle of pre-heaters is to heat the passenger compartment of all kinds of vehicles without having to depend on the heat given off by a running engine. That's a well-known fact. But at some point or other you must have asked yourself what the actual difference is between air and water heaters.

AIR-BASED PRE-HEATERS – EBERSPÄCHER AIRTRONIC:

Air-based pre-heaters are mostly installed inside the cab and directly heat the air inside it, which is sucked in via the unit's own fan. Their effects are noticeable almost instantly, as the heat in the form of hot gas, which is produced by a burner, does not have to heat up a water circuit first. Modern devices are very quiet, low on emissions and chiefly used to maintain the temperature in the cab of a truck or transporter at a pleasant level even while it is at a standstill (e.g. overnight).

WATER-BASED PRE-HEATERS – EBERSPÄCHER HYDRONIC:

Water-based pre-heaters have a compact design and can be fitted almost anywhere in the engine compartment. They are therefore the pre-heater of choice for cars with interiors too cramped for additional installations. The heat generated by a burner is transferred to the vehicle's cooling water. An (additional) electric circulation pump distributes the heat, even when the engine is switched off. Then, the interior fan is activated automatically – everything works as it does

in normal heater operation. Water-based heaters therefore not only warm up the interior, but also heat the engine or the water used in boats or motorhomes. Engines heated in this way can be started more easily in cold weather while also protecting the car battery from the effects of the cold, and producing fewer harmful emissions on starting, as the hotter exhaust temperature enables the catalytic converter to reach its operating temperature more quickly. The cold-start phase, which produces mechanical stress and higher emissions, is dramatically reduced, as the oil reaches operating temperature fast when the engine is started. This saves fuel and money on the one hand, and lowers CO₂ emissions on the other.

Both systems generally run on the vehicle's fuel, straight out of the fuel tank. Depending on the model, heaters can be activated with a timer switch, radio remote control or cellphone.

1

2

3

4

5

6

7

8

9

10

11

12

13

1 | HEATING SYSTEMS: HYDRONIC – WATER HEATERS

HYDRONIC 4 KW:

Cab and engine heater



Passenger cars (up to 2.0 l displacement)



Emergency vehicles



Station wagons (with additional thermo-combi valve if using Hydronic 4; ideally use Hydronic 5)



Small construction and agricultural machinery (D only)



Motor yachts up to around 22 ft long

HYDRONIC 5 KW (INCL. HYDRONIC 2 COMFORT):

Cab and engine heater



Passenger cars, station wagons (up to 2.5 l displacement; for 2.6 l displacement or greater we always recommend the Hydronic 2 Comfort)



Emergency vehicles



Vans, large taxis, minivans



Commercial vehicles, including tandem configurations with air heaters



Construction and agricultural machinery (D only)



Motor yachts up to approx. 25 ft long

HYDRONIC M8/M10/M12



Commercial vehicles from approx. 150 kW engine power



Cargo area heating



Military vehicles



Large agricultural and construction machinery



Motor yachts up to approx. 45 ft long

HYDRONIC L16/L24/L30/L35:



City and tour buses



Large freight compartments for goods which need to be kept warm



Container setups



Diesel locomotives



Yachts and ships up to approx. 72 ft long

1

2

3

4

5

6

7

8

9

10

11

12

13

1 | HEATING SYSTEMS: AIRTRONIC – AIR HEATERS

AIRTRONIC D2:

Heating comfort for a variety of applications.



Truck cabs with sleeping cabins



Construction and agricultural machinery without engine-dependent heating



Forklifts and other plant machinery



Electric vehicles



Yachts up to approx. 22 ft long

AIRTRONIC D4/D4 PLUS/B4:

The high-performance, compact air heater for mid-range requirements.



Large trucks – cabs with sleeping cabins



Vans, small buses



Large agricultural and construction machinery



Yachts up to approx. 35 ft long

AIRTRONIC D3:

For demanding long-term heating requirements. Quiet and energy-saving.



Motorhomes



Minivans, and vehicles used for conferences and consultancy



Large truck/luxury cabs with sleeping cabins

AIRTRONIC D5/B5:

TRS-enabled, continuously variable, pre-selectable interior temperature regulation.



Vans, workshop vehicles and personnel carriers, small buses (fast heating despite door opening frequently)



Ambulances and emergency medics' vehicles special heating and temperature requirements



Freight compartment and freight goods heating plus frost protection and dew point prevention



Yachts and ships up to approx. 45 ft long

D8 LC:

Continuously variable, pre-selectable interior temperature regulation.



Large freight compartments, containers



Personnel carriers



Coaches and city buses



Ships up to approx. 62 ft long

- 1
- 2
- 3
- 4
- 5
- 6
- 7
- 8
- 9
- 10
- 11
- 12
- 13

2 | HYDRONIC: TECHNOLOGY

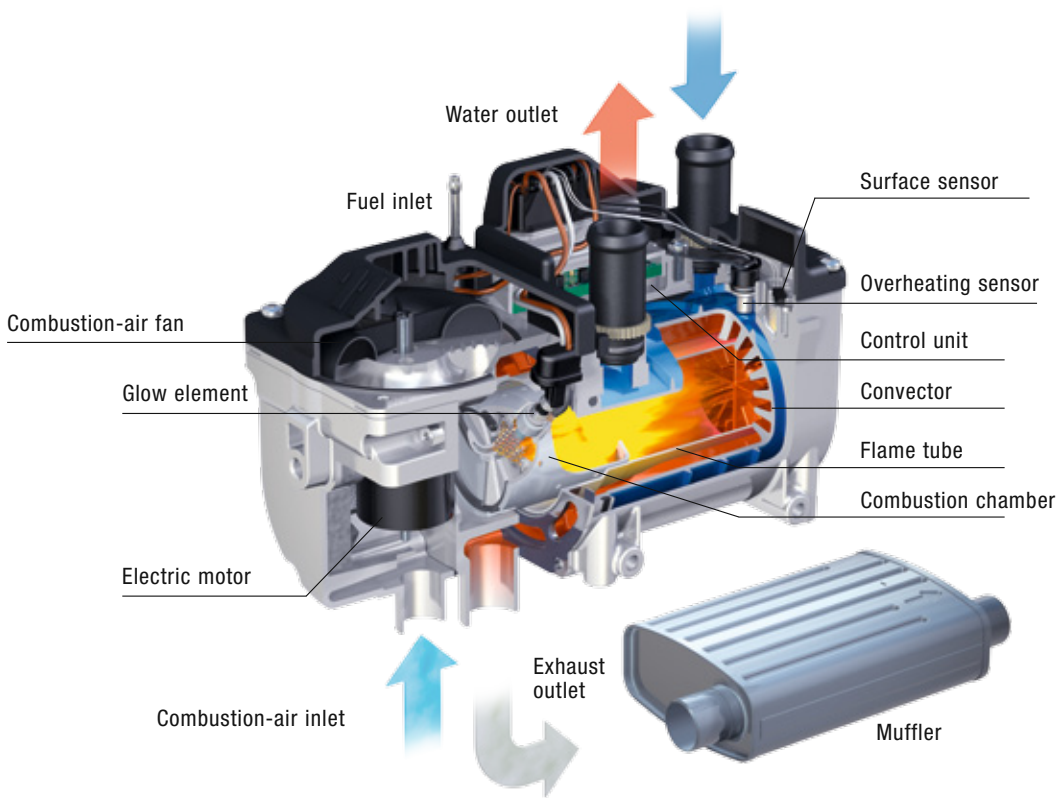

HYDRONIC, HYDRONIC 2 (ECONOMY AND COMFORT) AND HYDRONIC M FUNCTIONS:

- Combustion air is conveyed to the combustion chamber by the fan motor and impeller.
- Fuel is drawn from the vehicle's tank.
- Fuel is conveyed to the combustion chamber by the metering pump (reciprocating pump).
- The glow element vaporizes this fuel as it enters the combustion chamber and creates a combustible fuel-air mix with the combustion air.
- The resulting flame formation switches off the glow element, transfers the heat to the cooling water via the convector, and diverts exhaust gas via the exhaust muffler.
- The cooling water circulation pump conveys cool water to the heater, where it is warmed by the convector and then routed to the vehicle's own convector and combustion engine.

2 | HYDRONIC 2 COMFORT: TECHNOLOGY

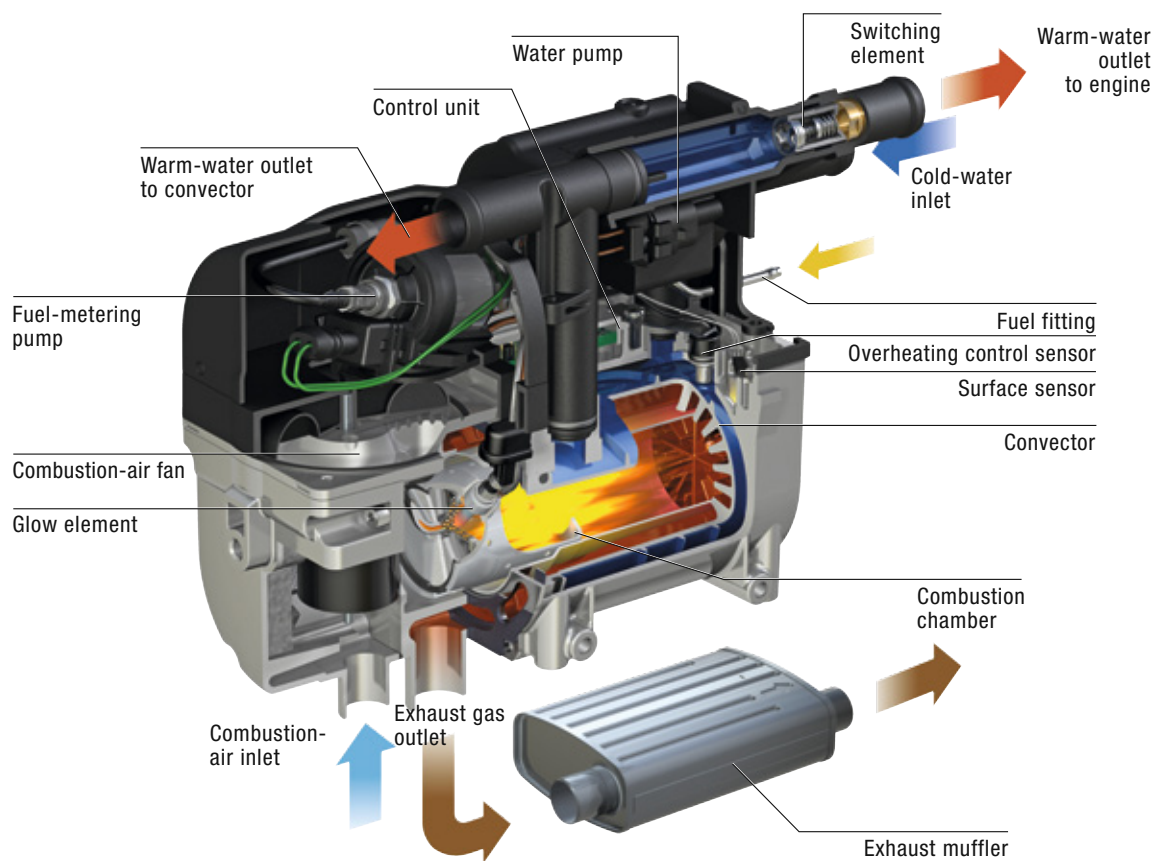

HYDRONIC 2 COMFORT FUNCTIONS:

- See Hydronic functions (page opposite)
- The Hydronic 2 Comfort has an inbuilt thermostat valve in the comfort circuit which ensures that the vehicle interior is warmed first. When the cooling water temperature is at least 67°C the valve then opens the wider circuit in order to route heat to the vehicle's combustion engine. By this point the vehicle interior has already reached a temperature which enables the windows to thaw completely.
- The Hydronic 2 Comfort is therefore absolutely ideal for short-distance car drivers, as the short heating time puts less load on the vehicle battery.

1

2

3

4

5

6

7

8

9

10

11

12

13

2 | HYDRONIC L: TECHNOLOGY

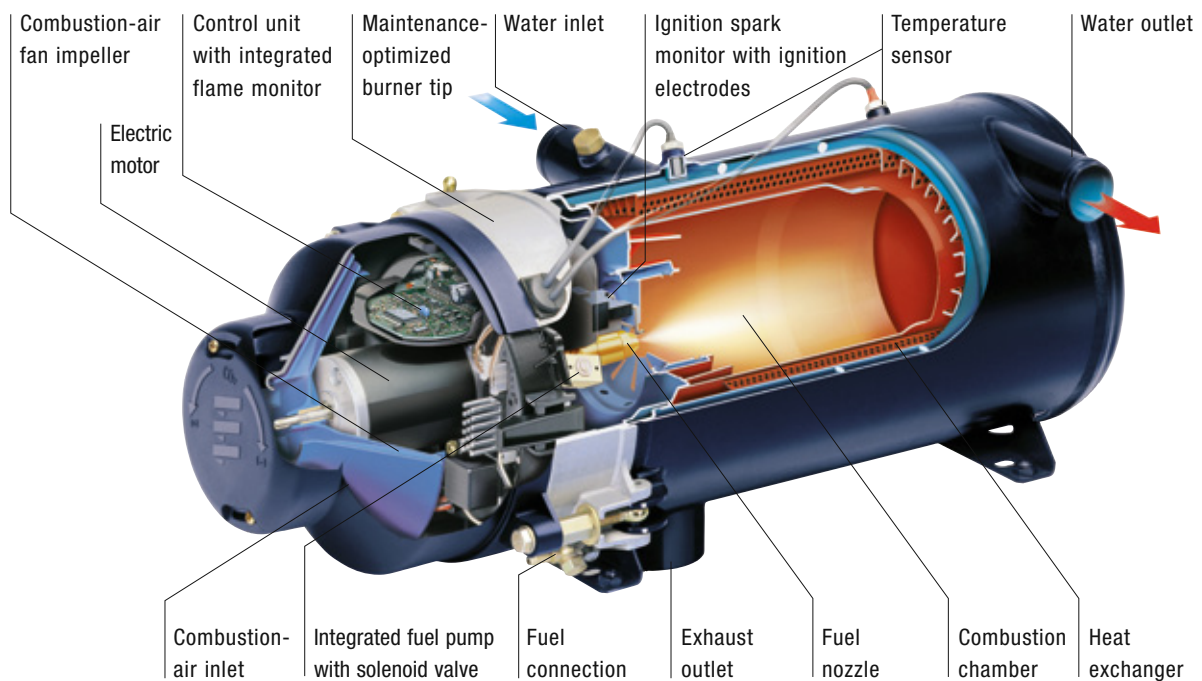

HYDRONIC L FUNCTIONS:

- Combustion air is conveyed to the combustion chamber by the fan motor and impeller.
- A gear pump conveys fuel from the vehicle's tank and builds up pressure against the closed solenoid valve.
- The solenoid valve opens and the fuel is atomized by the fuel nozzle in the combustion chamber/flame tube.
- The ignition spark monitor ignites the fuel-air mix.
- The resulting flame detection by an optical flame sensor switches off the ignition spark monitor, transfers the heat to the cooling water via the convector, and diverts exhaust gas via the exhaust muffler.
- The cooling water circulation pump conveys cool water to the heater, where it is warmed by the convector and then routed to the vehicle's own convector and combustion engine.

1

2

3

4

5

6

7

8

9

10

11

12

13

EBERSPÄCHER HYDRONIC



Heater	Hydronic B4W S	Hydronic B5W S	Hydronic B4W SC	Hydronic B5W SC
Product package	Heater OR complete package*	Heater OR complete package*	Heater OR complete package*	Heater OR complete package*
Techn. designation	Hydronic B4W S	Hydronic B5W S	Hydronic B4W SC	Hydronic B5W SC
Order no. for heater	20 1852 05 00 00	20 1819 05 00 00	20 1824 05 00 00	20 1820 05 00 00
Order no. for complete package*	20 1866 05 00 00	20 1862 05 00 00	20 1861 05 00 00	20 1863 05 00 00
Fuel	Gasoline	Gasoline	Gasoline	Gasoline
Voltage V	12	12	12	12
Heating medium	Water	Water	Water	Water
Control/heat settings	low/high	low/high	low/high	low/high
Heat output W	1,500/4,300	1,500/5,000	1,500/4,300	1,500/5,000
Fuel consumption l/h	0.2/0.6	0.2/0.69	0.2/0.6	0.2/0.69
Elec. power consumption, operation W	10/35	10/37	22/48	22/50
Elec. power consumption, start W	110	110	120	120
Minimum water throughput l/h	250	250	250	250
Lower voltage limit V	10.2	10.2	10.2	10.2
Upper voltage limit V	16	16	16	16
Interference suppression	5 (DIN 57879/VDE 0879 Part 1)	5 (DIN 57879/VDE 0879 Part 1)	5 (DIN 57879/VDE 0879 Part 1)	5 (DIN 57879/VDE 0879 Part 1)
Dimensions L x W x H mm	220 x 86 x 101.5	220 x 86 x 101.5	220 x 86 x 160	220 x 86 x 160
Weight empty kg	2.3	2.3	2.7	2.7

* Complete package: heater incl. universal installation kit (IK)

EBERSPÄCHER HYDRONIC







Heater	Hydronic D4W S	Hydronic D5W S	Hydronic D4W SC	Hydronic D5W SC
Product package	Heater OR complete package*	Heater OR complete package*	Heater OR complete package*	Heater OR complete package*
Techn. designation	Hydronic D4W S	Hydronic D5W S	Hydronic D4W SC	Hydronic D5W SC
Order no. for heater	25 2355 05 00 00	25 2217 05 00 00	25 2257 05 00 00	25 2219 05 00 00
Order no. for complete package*	25 2418 05 00 00	25 2386 05 00 00	25 2385 05 00 00	25 2390 05 00 00
Fuel	Diesel	Diesel	Diesel	Diesel
Voltage V	12	12	12	12
Heating medium	Water	Water	Water	Water
Control/heat settings	low/high	low/high	low/high	low/high
Heat output W	2,400/4,300	2,400/5,000	2,400/4,300	2,400/5,000
Fuel consumption l/h	0.27/0.53	0.27/0.62	0.27/0.53	0.27/0.62
Elec. power consumption, operation W	10/35	10/37	23/48	23/50
Elec. power consumption, start W	110	110	120	120
Minimum water throughput l/h	250	250	250	250
Lower voltage limit V	10.2	10.2	10.2	10.2
Upper voltage limit V	16	16	16	16
Interference suppression	5 (DIN 57879/VDE 0879 Part 1)	5 (DIN 57879/VDE 0879 Part 1)	5 (DIN 57879/VDE 0879 Part 1)	5 (DIN 57879/VDE 0879 Part 1)
Dimensions L x W x H mm	220 x 86 x 101.5	220 x 86 x 101.5	220 x 86 x 160	220 x 86 x 160
Weight empty kg	2.3	2.3	2.9	2.9

*Complete package: heater incl. universal installation kit

- 1
- 2
- 3
- 4
- 5
- 6
- 7
- 8
- 9
- 10
- 11
- 12
- 13

					
EBERSPÄCHER HYDRONIC					
Heater		Hydronic D5W S	Hydronic D5W SC	Hydronic 2 Comfort	Hydronic 2 Comfort
Product package		Heater	Heater	Heater	Heater
Techn. designation		Hydronic D5W S	Hydronic D5W SC	B 5 SC	D 5 SC
Order no. for heater		25 2218 05 00 00	25 2147 05 00 00	20 1928 05 00 00	25 2598 05 00 00
Fuel		Diesel	Diesel	Gasoline and E85	Diesel and FAME*
Voltage	V	24	24	12	12
Heating medium		Water	Water	Water	Water
Control/heat settings		low/high	low/high	low/high/power	low/high/power
Heat output	W	2,400/5,000	2,400/5,000	2,300/5,000/5,200	2,100/5,000/5,200
Fuel consumption	l/h	0.27/0.62	0.27/0.62	0.32/0.69/0.72	0.26/0.61/0.64
Elec. power consumption, operation	W	10/37	23/50	22/47/50	22/47/50
Elec. power consumption, start	W	110	120	130	130
Minimum water throughput	l/h	250	250	250	250
Lower voltage limit	V	20.4	20.4	10.5	10.5
Upper voltage limit	V	32	32	16	16
Interference suppression		5 for VHF/SW/MW, 2 for LW	5 (DIN 57879/VDE 0879 Part 1)	5 (DIN EN 55025)	5 (DIN EN 55025)
Dimensions L x W x H	mm	220 x 86 x 101.5	220 x 86 x 160	262 x 90 x 184	262 x 90 x 184
Weight empty	kg	2.3	2.9	2.7	2.9

* Diesel with max. 20% FAME

					
EBERSPÄCHER HYDRONIC					
Heater		Hydronic 2 Economy B4S	Hydronic 2 Economy B5S	Hydronic 2 Economy D4S	Hydronic 2 Economy D5S
Product package		Heater	Heater	Heater (with or without APRMP)	Heater (with or without APRMP)
Techn. designation		B4S 12V	B5S 12V	D4S 12V DP	D5S 12V DP
Order no. for heater		20 1909 05 00 00	20 1904 05 00 00	25 2554 05 00 00	25 2526 05 00 00
Order no. for heater with APRMP*				25 2558 05 00 00	25 2557 05 00 00
Fuel		Gasoline and E85	Gasoline	Diesel	Diesel
Voltage	V	12	12	12	12
Heating medium		Water	Water	Water	Water
Control/heat settings		low/high/power	low/high/power	low/high/power	low/high/power
Heat output	W	2,300/4,000/4,400	2,300/5,000/5,200	2,100/4,100/4,300	2,100/5,000/5,200
Fuel consumption	l/h	0.32/0.55/0.62	0.32/0.69/0.72	0.26/0.5/0.52	0.26/0.61/0.64
Elec. power consumption, operation	W	12/21/27	12/37/40	12/21/27	12/37/40
Elec. power consumption, start	W	120	120	120	120
Minimum water throughput	l/h	250	250	250	250
Lower voltage limit	V	10.5	10.5	10.5	10.5
Upper voltage limit	V	16	16	16	16
Interference suppression		5 (DIN EN 55025)	5 (DIN EN 55025)	5 (DIN EN 55025)	5 (DIN EN 55025)
Dimensions L x W x H	mm	214 x 86 x 139	214 x 86 x 139	214 x 86 x 139	214 x 86 x 139
Weight empty	kg	2.4	2.4	2.4	2.4

* APRMP = pressure-resistant metering pump



EBERSPÄCHER HYDRONIC

Heater	Hydronic 2 Ethanol E4S		
Product package	Heater		
Techn. designation	E4S 12V		
Order no. for heater	20 1920 05 00 00		
Fuel	E85 bio-ethanol according to DIN 51625/E100		
Voltage	V	12	
Heating medium	Mixture of water and (max 50 %) coolant		
Control/heat settings	low/high/power		
Heat output	W	1,300/3,700/4,300	
Fuel consumption	l/h	0.23/0.67/0.78	
Elec. power consumption, operation	W	7/20/27	
Elec. power consumption, start	W	120	
Minimum water throughput	l/h	250	
Lower voltage limit	V	10.5	
Upper voltage limit	V	16	
Interference suppression	5 (DIN EN 55025)		
Dimensions L x W x H	mm	214 x 86 x 139	
Weight empty	kg	2.4	



EBERSPÄCHER HYDRONIC

Heater	Hydronic M8 Biodiesel	Hydronic M8 Biodiesel	Hydronic M10	Hydronic M10
Product package	Heater		Heater	
Techn. designation	Hydronic M-II (D8W)		Hydronic M-II (D10W)	
Order no. for heater	25 2470 05 00 00	25 2471 05 00 00	25 2434 05 00 00	25 2435 05 00 00
Fuel	Diesel and FAME (biodiesel)		Diesel	
Voltage	V	12	24	12
Heating medium	Water		Water	
Control/heat settings	low/medium/high/power		low/medium/high/power	
Heat output	W	1,500/3,500/5,000/8,000	1,500/3,500/5,000/8,000	1,500/3,500/8,000/9,500
Fuel consumption	l/h	0.18/0.4/0.65/0.9	0.18/0.4/0.65/0.9	0.18/0.4/0.9/1.2
Elec. power consumption, operation	W	35/39/46/55	35/39/46/55	35/39/60/86
Elec. power consumption, start	W	200	200	120
Minimum water throughput	l/h	500	500	500
Lower voltage limit	V	10	20	10
Upper voltage limit	V	15	30	15
Interference suppression	5 (DIN EN 55025)			
Dimensions L x W x H	mm	331 x 138 x 221		331 x 138 x 221
Weight empty	kg	6.2		6.2

1

2

3

4

5

6

7

8

9

10

11

12

13



EBERSPÄCHER HYDRONIC

Heater		Hydronic M12	Hydronic M12
Product package		Heater	Heater
Techn. designation		Hydronic M-II (D12W)	Hydronic M-II (D12W)
Order no. for heater		25 2472 05 00 00	25 2473 05 00 00
Fuel		Diesel	Diesel
Voltage	V	12	24
Heating medium		Water	Water
Control/heat settings		low/medium 1/medium 2/medium 3/high/power	low/medium 1/medium 2/medium 3/high/power
Heat output	W	1,200/1,500/3,500/5,000/9,500/12,000	1,200/1,500/3,500/5,000/9,500/12,000
Fuel consumption	l/h	0.15/0.18/0.4/0.65/1.2/1.5	0.15/0.18/0.4/0.65/1.2/1.5
Elec. power consumption, operation	W	34/35/39/46/86/132	34/35/39/46/86/132
Elec. power consumption, start	W	120	120
Minimum water throughput	l/h	500	500
Lower voltage limit	V	10	20
Upper voltage limit	V	15	30
Interference suppression		5 (DIN EN 55025)	5 (DIN EN 55025)
Dimensions L x W x H	mm	331 x 138 x 221	331 x 138 x 221
Weight empty	kg	6.2	6.2

EBERSPÄCHER HYDRONIC



Heater		Hydronic L16	Hydronic L24	Hydronic L30	Hydronic L35
Product package		Heater	Heater	Heater	Heater
Techn. designation		Hydronic L-II (HL2-16)	Hydronic L-II (HL2-24)	Hydronic L-II (HL2-30)	Hydronic L-II (HL2-35)
Order no. for heater		25 2486 02 00 00	25 2487 02 00 00	25 2599 02 00 00	25 2600 02 00 00
Order no. for compact heater		—	25 2487 05 00 00	25 2599 05 00 00	25 2600 05 00 00
Fuel		Diesel and fuel oil	Diesel and fuel oil	Diesel and fuel oil	Diesel and fuel oil
Voltage	V	24	24	24	24
Heating medium		Water	Water	Water	Water
Heat output	W	16,000	24,000	30,000	35,000
Fuel consumption	l/h	2	2.9	3.65	4.2
Elec. power consumption, operation	W	60	80	105	120
Minimum water throughput	l/h	1,400	2,000	2,600	3,000
Lower voltage limit	V	20	20	20	20
Upper voltage limit	V	30	30	30	30
Interference suppression		4 for VHF/SW/LW, 5 for MW	4 for VHF/SW/LW, 5 for MW	4 for VHF/SW/LW, 5 for MW	4 for VHF/SW/LW, 5 for MW
Dimensions L x W x H	mm	600 x 230 x 222	600 x 230 x 222	600 x 230 x 222	600 x 230 x 222
Weight empty**	kg	18	18	18	18

EBERSPÄCHER WATER PUMPS FOR HYDRONIC



Water pumps	Flowtronic 5000*	Flowtronic 5000 S	Flowtronic 6000 SC
Order no. for water pump	25 2488 26 00 00	25 1818 30 00 00	25 2488 25 00 00
Coolant	Water-glycol mix with up to max 50 % glycol	Water-glycol mix with up to max 50 % glycol	Water-glycol mix with up to max 50 % glycol
Delivery rate l/h	5,200 at 0.2 bar	5,200 at 0.2 bar	6,000 at 0.4 bar
Operating pressure bar	max. 2	max. 2	max. 2
Nominal voltage V	24	24	24
Elec. power consumption W	104	104	210
Protection class	IP5K4	IP54A	IP25 (potted electronics)
Dry running	No	No	Yes – motor switches itself off after 45 minutes
Shaft-impeller connector	Mechanical seal	Magnetic coupling	Magnetic coupling
Weight empty* kg	2.04	2.2	2.5

* Without mounting bracket, clamp and coolant

1

2

3

4

5

6

7

8

9

10

11

12

13

2 | HYDRONIC: WATER-HEATER RANGE FOR CARS

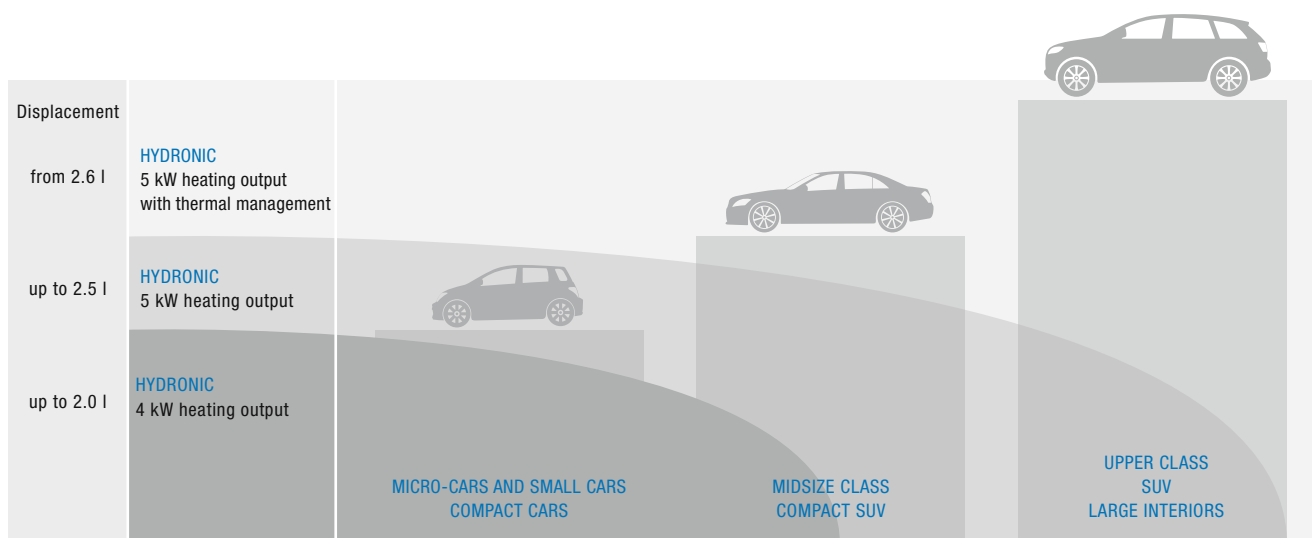

ADVANTAGES:

- Hydronic 4 SC/5 SC: Faster installation.
- Hydronic 4 S/5 S or Hydronic 2 Economy without APRMP (pressure-resistant metering pump): Space-saving heater for cramped installation spaces, as the water and metering pumps can be installed separately.
- Hydronic 2 Economy APRMP (pressure-resistant metering pump): Faster installation as there is no need to remove the tank. Please see the relevant installation recommendations, plus optional additions on page 24, for the range of cars for which this equipment is suitable.
- Hydronic 2 Comfort: Faster installation if thermal management is required. There is no need to install a separate comfort installation kit.
- The Biodiesel M8, Standard M10 and Hydronic M12 provide increased power for larger engines and cabins, e.g. large trucks, small buses, cargo areas.
- The Hydronic L, 16–35 kW, is ideally suited for buses, trains, boats and cargo areas.

FUEL COMPATIBILITY:





- Multifuel E85:** The Hydronic 2 B5S and B5SC with fuel kit (E85 kit) for heating electric vehicles and multifuel vehicles; fuel kit order number 22 1000 20 31 00.
- Biodiesel:** Hydronic 2 Economy (up to 20 %), Hydronic 2 Comfort (up to 20 %), Hydronic (up to 10 %), Hydronic M8 (100 %), Hydronic M10/M12 (up to 20 %).
- E10:** all (professionally installed) water heaters.

EXPERT TIPS FOR INSTALLING THE PRESSURE-RESISTANT

METERING PUMP: You need to know the fuel pressure and temperature. The end of the fuel return line must be just above the floor of the tank and must not be fitted with a check valve. Diesel vehicles can then be connected straight to the return line. Please also always take note of the technical description of the particular equipment.

2 | HYDRONIC: VEHICLE-SPECIFIC ADDITIONAL PARTS

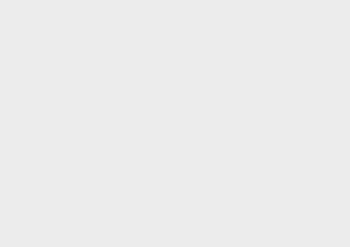
The product package for individual devices generally includes the heater itself, the fuel-metering pump and the water pump. For retrofitting vehicles for which Eberspächer provides installation recommendations, a vehicle-specific installation kit (IK) and, if applicable, an air-conditioning kit are also required.

<p>Heater</p>	<ul style="list-style-type: none"> ▪ Contents ▪ Heater ▪ Water pump ▪ Metering pump 	
<p>Vehicle-specific installation kit</p>	<ul style="list-style-type: none"> ▪ Heater mounting bracket ▪ Water hoses ▪ Fuel lines ▪ Wiring harness ▪ Combustion-air hose ▪ Exhaust hose with muffler ▪ A/C kit if applicable 	
<p>A/C kit</p>	<ul style="list-style-type: none"> ▪ Pre-assembled wiring harness ▪ Relay ▪ IPCU (see also Service, options with IPCU, if there is no A/C kit) 	
<p>Control element</p>	<ul style="list-style-type: none"> ▪ Easy Start Select/Timer/Remote/Remote+ 	

- 1
- 2
- 3
- 4
- 5
- 6
- 7
- 8
- 9
- 10
- 11
- 12
- 13

2 | HYDRONIC: COMPLETE PACKAGES/UNIVERSAL INSTALLATION KITS

The following table shows the housing types and product packages of the various water heater models along with their corresponding installation kits. In contrast with individual devices, complete packages include the heater (incl. fuel-metering and water pump) and universal installation kit. The universal installation kit includes a host of (vehicle independent) parts required for installation. In this case, additional vehicle-specific installation parts are required which are not listed in the respective installation recommendations. If Eberspächer Provides no installation recommendations for a particular vehicle, you can still retrofit a pre-heater using a complete package (see also the next section, "Hydronic: Retrofit parts range for passenger cars", step 4B). S-models have a space-saving housing design, with the fuel-metering and water pump mounted on the outside. SC-models generally have the water pump on the inside of the equipment, and on diesel heaters the fuel-metering pump is also on the inside. For gasoline versions the fuel-metering pump is generally installed on the outside.

Water heaters	Heater	Individual devices	Complete package	Vehicle-specific IK A/C kit if applicable (new)	Vehicle-specific IK (old)	Universal IK
Hydronic	20 1852 05 00 00	x		x		24 9988 00 00 64*
	20 1819 05 00 00	x		x		
	20 1824 05 00 00	x		x		
	20 1820 05 00 00	x		x		
	25 2355 05 00 00	x		x		25 2218 80 00 00
	25 2217 05 00 00	x		x		
	25 2218 05 00 00	x				
	25 2257 05 00 00	x			x	
	25 2219 05 00 00	x			x	
	25 2147 05 00 00	x				25 2009 80 00 00
	20 1866 05 00 00		x		x	
	20 1862 05 00 00			x	x	
	20 1861 05 00 00			x		
	20 1663 05 00 00			x	x	
	25 2418 05 00 00			x		
25 2386 05 00 00			x	x		
25 2385 05 00 00			x			
25 2390 05 00 00			x	x		
Hydronic 2 Economy	25 2558 05 00 00	x		x		25 2526 81 00 00
	25 2554 05 00 00	x		x		
	25 2557 05 00 00	x		x		
	25 2526 05 00 00	x		x		
	20 1909 05 00 00	x		x		
	20 1904 05 00 00	x		x		
Hydronic 2 Ethanol E4S	20 1920 05 00 00	x		x		20 1920 82 00 00
		x		x		20 1920 83 00 00**
Hydronic 2 Comfort	20 1928 05 00 00	x		x		25 2598 80 00 00
	25 2598 05 00 00	x		x		
Hydronic M2	25 2470 05 00 00	x				25 2435 81 00 00
	25 2471 05 00 00	x				
	25 2434 05 00 00	x				
	25 2435 05 00 00	x				
	25 2472 05 00 00	x				
	25 2473 05 00 00	x				

* applies to all 12 V Hydronic water heaters

** IK with cat.



2 | HYDRONIC: RETROFIT PARTS RANGE FOR PASSENGER CARS

INSTALLATION OF THE HYDRONIC WATER HEATER/HYDRONIC 2 WITH 4 OR 5 KW HEATING OUTPUT:

1 | REGISTERING ON THE ONLINE SERVICE PORTAL

Log into the Eberspächer Service Portal with your personal access details (login and password):
<http://partner.eberspaecher.com>

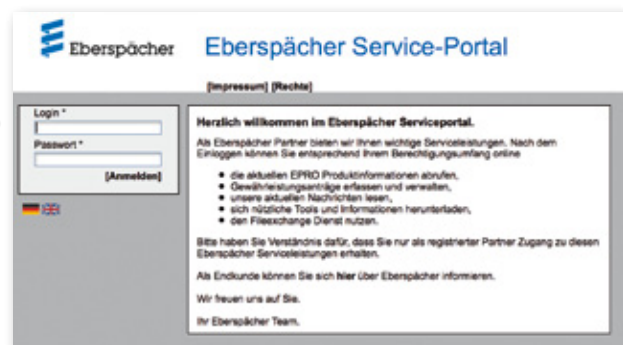

2 | "EPRO" AREA

Then select the "EPRO tab.

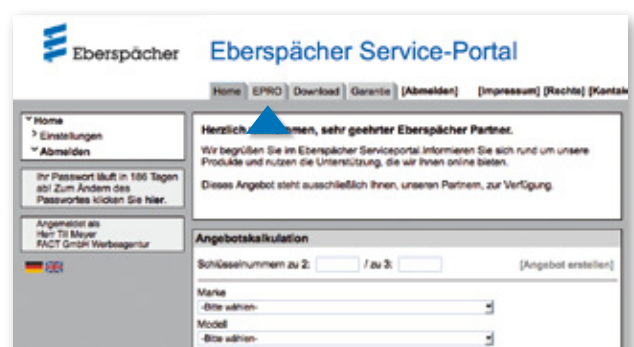

1

2

3

4

5

6

7

8

9

10

11

12

13

3 | INPUT VEHICLE TYPE OR KBA KEY*

Using the drop down menu to the left of the window, select the right vehicle or input the KBA key number* ("at 2/3") of the vehicle in the relevant fields and click the **[Go]** button.

Schlüsselnr./KBA-Nr. zu 2/3
 / **[Go]**

Einbauvorschläge/OEM Info
 Einbauvorschläge
 OEM Einbauinfo

Übersicht in Listform

Schlüsselnr./KBA-Nr. zu 2/3
 / **[Go]**

Fahrzeugtyp
 PKW/NFZ

Marke
 -Bitte wählen-

Modell
 -Bitte wählen-

Motor
 -Bitte wählen-

Kraftstoffart
 -Bitte wählen-

[Go]

* KBA key numbers are only used in Germany

4A | THERE IS AN INSTALLATION RECOMMENDATION FOR THE VEHICLE

If there is an installation recommendation for retrofitting the vehicle, the vehicle model will be displayed in the middle window with information on the recommended heater including the price (excl. sales tax). Click on the vehicle in the window. The parts required for the installation are now displayed in the right-hand window.

- Recommended **heater** (incl. water pump and fuel-metering pump)
- **Control element** (of your choice)
- **Vehicle-specific installation kit** including all parts required for the mechanical installation
- **A/C kit** if applicable (for models with automatic air conditioning)
- Additional installation parts if applicable

If you click the **[Get estimate]** button, this will take you to the estimates area where you can obtain a quote.

Eberspächer Eberspächer Service-Portal

Home | EPNO | Downloads | Garantie | Abmelden | Impressum | Recht | Kontakt

Technik
 > Hauptseite
 > Zubehör
 > Einbausatz
 > Fahrzeugtyp
 > Einbauvorschläge/OEM Info

Übersicht in Listform
 Schlüsselnr./KBA-Nr. zu 2/3
 / **[Go]**

Fahrzeugtyp
 PKW/NFZ

Marke
 AUDI

Modell
 A1 (8E, 2010-)

Motor
 A1 (2.0 TFSI) (150 kW) (05.2010-)

Einbauvorschlag (Wählen Sie Daten)

Fahrzeug
 AUDI A1 (1.6 TFSI) (90 kW) (05.2010-)

Einbauvorschlag
 AUDI A1 (1.6 TFSI) (90 kW) (05.2010-)

Bezeichnung	Menge	Preis	Bild
Hydronic 2 800 12V	1,00	644,16 €	
Komplet-Audit A1	1,00	79,80 €	
Einbauinfo	1,00	100,74 €	
Einbauinfo		8,25 €	

[Get estimate]

Die Angebote übernehmen! (Kassenzettel aufheben!)

4A | THERE IS NO INSTALLATION RECOMMENDATION FOR THE VEHICLE

EXPERT TIPS

If there is no installation recommendation, a message will appear in the middle window to tell you. However, it may still be possible to retrofit an Eberspächer pre-heater in the selected vehicle. The following parts are required for installation without an installation recommendation:

Option 1 (with a Hydronic heater):

- **Complete Hydronic heater package** (see also the sections on "Complete packages/universal installation kits", "Device range")
- **Control element** (of your choice) + additional installation parts if applicable

Option 2 (with Hydronic 2 heater):

- **Hydronic 2 heater** including water pump and fuel-metering pump (see also the sections on "Complete packages/universal installation kits", "Device range")
- **Universal installation kit** for Hydronic 2 + additional installation parts if applicable
- **Control element** (of your choice)

Eberspächer Eberspächer Service-Portal

Home | EPNO | Downloads | Garantie | Abmelden | Impressum | Recht | Kontakt

Technik
 > Hauptseite
 > Zubehör
 > Einbausatz
 > Fahrzeugtyp
 > Einbauvorschläge/OEM Info

Übersicht in Listform
 Schlüsselnr./KBA-Nr. zu 2/3
 / **[Go]**

Fahrzeugtyp
 PKW/NFZ

Marke
 AUDI

Modell
 A1 (05.2010-)

Motor
 A1 (2.0 TFSI) (150 kW) (05.2010-)

Einbauvorschlag (Wählen Sie Daten)

Fahrzeug
 AUDI A1 (1.2 TFSI) (63 kW) (05.2010-)

Einbauvorschlag
 AUDI A1 (1.2 TFSI) (63 kW) (05.2010-)

Für dieses Modell ist leider kein Einbauvorschlag vorhanden.

2 | HYDRONIC: RETROFIT PARTS RANGE

INSTALLATION OF THE HYDRONIC M WATER HEATER WITH 8–12 KW HEATING OUTPUT:

Installation parts for the **Hydronic M** heaters are usually heavily application-dependent. Planning installation of these heaters requires not only the heater and universal installation kit but also, where applicable, additional installation parts that need to be determined during installation planning. Please see the section on “Accessories” for the corresponding additional parts. For example, with convector and boiler installations, a wide range of heating options can be used in parallel.

Hydronic M heater installations generally require the following parts:

- Hydronic M heater with 8 kW, 10 kW or 12 kW output, 12 or 24 V
- Hydronic M universal installation kit
- Control element (of your choice)
- Additional installation parts based on application, if applicable (see also “Accessories” section)

See also the sections on “Complete packages/universal installation kits”, “Device range” and “Control elements”.

INSTALLATION OF THE HYDRONIC L WATER HEATER WITH 16–35 KW HEATING OUTPUT:

Installation parts for the **Hydronic L** heaters are also heavily application-dependent. As a result there is no universal installation kit for these heaters.

Alongside the heater, installation planning needs to include some additional installation parts which have to be specified during planning. Please see the section on “Accessories” for the corresponding additional parts. Again, for example, there is a host of heating options that can be used in parallel in convector and boiler installation.

The **24 kW, 30 kW and 35 kW heater variants** are available individually as well as in a compact version. To make heater installation easier the compact version comes with the water pump and fuel filter and their installation parts pre-installed.

- Hydronic L 16 kW, 24 kW, 30 kW or 35 kW heater as individual device or compact version
- Additional parts for connecting the water circuit
- Additional parts for the fuel supply
- Additional parts for the exhaust system
- Control element (of your choice)

See also the sections on “Device range” and “Control elements”.

Our **Technical Hotline** can provide you with advice and support on this: **Phone: 0180 5 26 26 26**

(14 ct./min. bei Anrufen aus dem deutschen Festnetz. Mobilfunk deutlich teurer)

1

2

3

4

5

6

7

8





9

10

11

12

13

					
CONTROL ELEMENTS					
Model	EasyStart Select Control unit	EasyStart Timer Timer	EasyStart Remote Remote control	EasyStart Remote+ Remote control	EasyStart Call* Telephone remote control
Order number	22 1000 34 13 00	22 1000 34 15 00	22 1000 34 23 00	22 1000 34 17 00	22 1000 34 01 00
Description	Basic version	Comfort version	Basic version	Comfort version	Operated by voice menu, text message, or smartphone app (available for iPhone and Android)
Functions	<ul style="list-style-type: none"> Heating/ventilation on/off 	<ul style="list-style-type: none"> Heating/ventilation on/off Additional device on/off Program/delete pre-select mode Press and hold the function for immediate heating A second heater can be operated 	<ul style="list-style-type: none"> Heating/ventilation on/off Operating time adjustable 	<ul style="list-style-type: none"> Heating/ventilation on/off Additional device on/off Program/delete pre-select mode Press and hold the function for immediate heating A second heater can be operated 	<ul style="list-style-type: none"> Heating/ventilation on/off
Timer programming	–	<ul style="list-style-type: none"> Three programming locations within seven days Selection of individual days of the week or one of three time periods (Mo.–Fr./Sa.+Su./Mo.–Su.) 	–	<ul style="list-style-type: none"> Three programming locations within seven days Selection of individual days of the week or one of three time periods (Mo.–Fr./Sa.+Su./Mo.–Su.) 	<ul style="list-style-type: none"> Three programming locations within seven days Selection of individual days of the week or one of three time periods (Mo.–Fr./Sa.+Su./Mo.–Su.)
Timer programming: auto. calculation of heating time	–	Optional with connection of temperature sensor	–	Yes	–
Immediate start-up mode running time	60 min. preset	Adjustable 10–120 min.	Adjustable 10, 20, 30, 40, 50 or 60 min.	Adjustable 10–120 min.	Adjustable 10–120 min.
Pre-ventilation**	Yes	Yes	Yes	Yes	Yes
Display interior temperature	–	Optional	–	Yes	Yes
Feedback	<ul style="list-style-type: none"> Status: Heater Status: Connection to the heater 	<ul style="list-style-type: none"> Status: Heater Status: Connection to the heater 	<ul style="list-style-type: none"> Data transfer successful Status: Heater Status: Connection to the heater 	<ul style="list-style-type: none"> Data transfer successful Status: Heater and Timer Status: Connection to the heater 	<ul style="list-style-type: none"> Status: Heater and timer Feedback by voice output or text message Status: Connection to the heater
Range	–	–	Up to 1 km under optimum conditions	Up to 1 km under optimum conditions	Unlimited (given network coverage)
Display	LED-illuminated ICON display. Lighting can be integrated with vehicle lighting circuit.	LED-illuminated matrix display. Lighting can be integrated with vehicle lighting circuit.	Two-tone LED	LED-illuminated matrix display	Display via smartphone app

* SIM card: 1.8-V or 3-V SIM card/pre-paid card from a network operator supporting the GSM 900/1800 (D-net, E-net) standard in Europe; use outside of country of purchase may incur roaming fees for EasyStart Call for outgoing or incoming text messages or incoming calls. Roaming fees may also be incurred near borders due to network overlap. EasyStart Call is not designed for use in conjunction with other control elements.

** Depending on heater type

1

2

3

4

5

6

7

8

9

10

11

12

13



2 | HYDRONIC: CONTROL ELEMENTS

ACCESSORIES

	EasyStart Select	EasyStart Timer	EasyStart Remote	EasyStart Remote+	EasyStart Call
Temperature sensor for displaying interior temperature	–	22 1000 34 22 00	–	Included in the product package	Included in the product package
Timer trim	–	22 1000 51 41 00	–	–	–

APPROVED COMBINATIONS OF CONTROL ELEMENTS

		SLAVE CONTROL ELEMENTS			
		EasyStart Select	EasyStart Timer	EasyStart Remote	Button
MASTER CONTROL ELEMENTS	EasyStart Timer	X	X	X	X
	EasyStart Remote+	X	X	–	Included in the product package

EasyStart Call:

Not currently designed for use in conjunction with other EasyStart control elements.

EasyStart Timer and EasyStart Remote+

APPROVED COMBINATIONS OF HEATER AND CONTROL ELEMENT:

OPTION 1

You can control a second heater by using the DAT line (purple) and the diagnostic line (blue and white). However, it is not possible to connect an additional control element. Diagnostics can be run for both heaters.

OPTION 2

You can switch on any device by activating the switch output (switch on/vehicle blower output). A second control element can be connected via the DAT line (purple). Diagnostics is available for the first heater but not for the second.

COMPATIBILITY MODE FOR HEATERS WITHOUT EBERSPÄCHER DIAGNOSTICS, E.G. HYDRONIC 24 V AND HYDRONIC L2

Heater diagnostics cannot be run via the control element.

1

2

3

4

5

6

7

8

9

10

11

12

13

2 | HYDRONIC: OPTIONAL ADD-ONS

ADDITIONAL HEATER KIT:

- Order number: 24 8532 00 0000
- Designation: ES additional heater kit for Hydronic 2 with EasyStart
- Area of application: Hydronic 2 Economy in combination with EasyStart

Expands pre-heater functionality for additional heating when driving (providing added value). The heating is switched on and off based on the outside temperature when the combustion engine is running. If the outside temperature is lower than around 5 °C the heating switches on, and switches off at higher temperatures.

PRE-VENTILATION OPTION:

- The Hydronic 12 V and Hydronic 2 Economy and Comfort have a pre-ventilation function
- Both this and the EasyStart control elements are automatically detected (see Commissioning EasyStart)

ALTITUDE KIT*:

Suitable for Hydronic and Hydronic 2 and is required from altitudes of around 1,500 m. When the heater starts, the pressure sensor measures the atmospheric pressure cyclically and sends the measured values to the heater control unit. The control unit evaluates the measured values and if required, adjusts the fuel feed in the metering pump to the current atmospheric pressure. It begins reducing fuel feed at around 1,400 m, which immediately starts to reduce heating power by around 9 % for every 1,000 m in altitude.

Check the compatibility of the heater, pressure sensor and control element before installation. (Please look for “H-Kit” on the heater identification label)

Technical data:

Max. permissible height: approx. 3,500 m

Measuring range: 600 hPa to 1,150 hPa

Nominal voltage: 12/24 V

Operating voltage: 8 to 32 V

Dimensions: 76 x 76 x 29 mm

Operating temperature: -40 °C to +85 °C

IDENTIFICATION LABEL:

1. In this case, on the right-hand side of the heater identification label you will see “H-Kit”. If the label carries this mark, the heater is suitable for automatic altitude adjustment.

2. The heater's packaging (box) carries a sticker on which you will find the drawing number of the heater: The last two characters of this number (e.g. “ON”) specify heater status. Based on this information, the Technical Hotline can tell you whether the heater is compatible with the altitude kit. If the label is not legible, please contact the Technical Hotline.

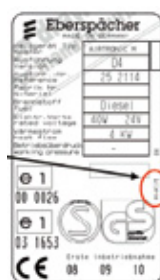

Fig.: Identification label



Fig.: Sticker on heater box

* The Hydronic M8, M10 and M12 feature the automatic altitude adjustment function. The heating can be operated up to altitudes of 3,500 m.

2 | HYDRONIC: OPTIONAL WATER CIRCUIT ON A HYDRONIC 2 EXAMPLE

1. IN-LINE WITH CHECK VALVE:

Advantage of “in-line integration”: no loss of performance on the vehicle heaters when the heater is switched off.

Please note! The check valve must be ordered separately – please refer to the additional parts catalog for the order number.

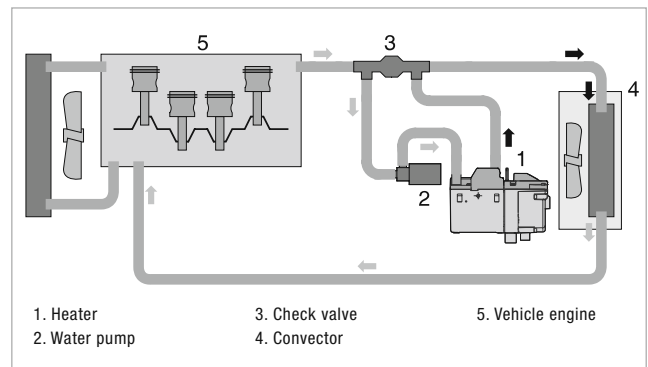

2. WATER CIRCUIT WITH COMFORT INSTALLATION KIT:

- Large engines > 2.5 l and/or large cabins
- Advantage: switches to full engine through-flow above 75 °C; installed in the engine compartment where there is always space

THERMOSTAT FUNCTION:

At a coolant temperature of < 70 °C – small cooling circuit:

- Fitting, position 1 – open (to heater)
- Fitting, position 2 – open (to T-piece)
- Fitting, position 3 – closed (to check valve)

At a coolant temperature of > 75 °C – large cooling circuit:

- Fitting, position 1 – open (to heater)
- Fitting, position 2 – closed (to T-piece)
- Fitting, position 3 – open (to check valve)

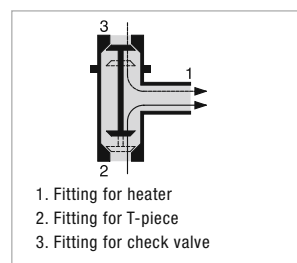
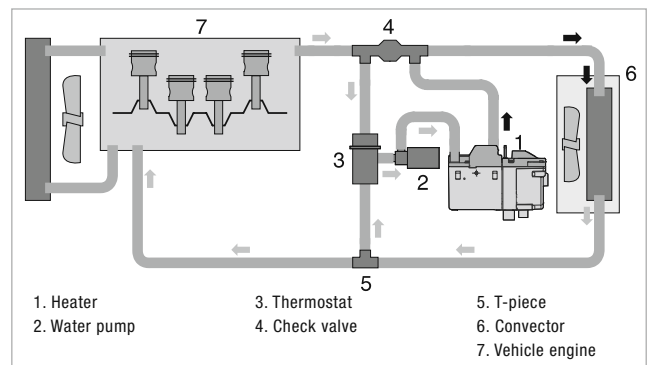

Please note! Integrate the thermostat with connections at positions 1, 2, and 3 – as shown in the drawing – into the cooling circuit. Based on a diameter of 20 mm.

HEATING CHARACTERISTIC:

Small cooling circuit: Until the coolant temperature reaches around 70 °C, the heater initially conveys heat to the vehicle’s own convector only, so that the vehicle interior heats up quickly.

Large cooling circuit: If the coolant temperature continues to rise, the thermostat gradually switches to the large circuit (switching over fully at around 75 °C), heating the vehicle interior and pre-heating the engine.

- 1
- 2
- 3
- 4
- 5
- 6
- 7
- 8
- 9
- 10
- 11
- 12
- 13

2 | HYDRONIC: OPTIONAL WATER CIRCUIT ON A HYDRONIC 2 EXAMPLE

3. WATER CIRCUIT WITH THERMAL COMBI VALVE:

- Large engines > 2.5 l and/or large cabins
- Small and compact cars, short distances
- Advantage: Switchover at 67 °C, variable cost-effective installation as combi valve with five or six connections
- Partial through-flow of engine from 67 °C
- Prioritizes cabin heat

INSTALLING A COMBI VALVE WITH FIVE CONNECTIONS:

Cut through the vehicle's water feed hose from the engine to the convector and insert the combi valve. Cut through the water return hose between the vehicle's convector and engine and insert the T-piece. Connect the heater and water pump and hoses to the combi valve and T-piece as shown in the drawing.

INSTALLING A COMBI VALVE WITH 6 CONNECTIONS:

Cut through the water feed and return hoses between the vehicle's engine and convector and insert the combi valve. Connect the heater and water pump and hoses to the combi valve as shown in the drawing.

HEATING CHARACTERISTIC IN PRE-HEATING MODE – SMALL COOLING CIRCUIT:

Until the coolant temperature reaches around 67 °C, the heater initially conveys heat to the vehicle's own convector only, so that the vehicle interior heats up quickly.

Once the coolant temperature reaches around 67 °C, some of the heat from the heater is also conveyed to the engine. This allows the engine to be pre-heated while preventing the small cooling circuit for interior heating from cooling too fast.

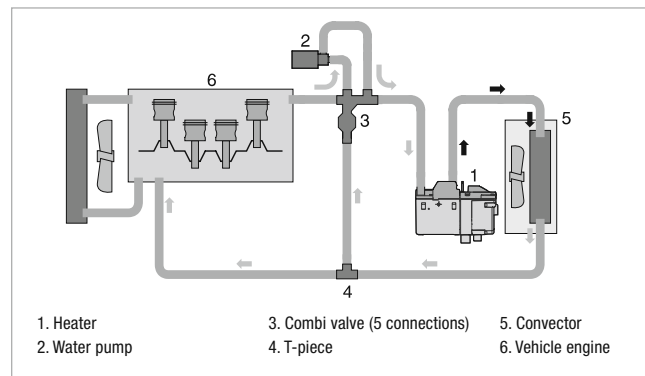

Combi valve (6 connections) water pump

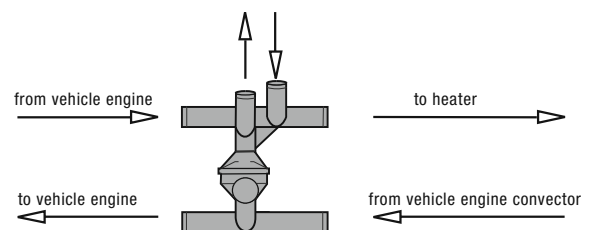

HEATING CHARACTERISTIC IN ADDITIONAL HEATING MODE – LARGE COOLING CIRCUIT:

When the engine is running, the heat from the vehicle's convector and engine are distributed equally, speeding up the warmup phase and the heating of the vehicle interior.

1

2

3

4

5

6

7

8

9

10

11

12

13

2 | HYDRONIC: OPTIONAL WATER CIRCUIT ON A HYDRONIC 2 EXAMPLE

RETROFIT KITS WITH WATER CHECK VALVE:

	Retrofit kit 1	Retrofit kit 2	Retrofit kit 3	Retrofit kit 4	Retrofit kit 5	Retrofit kit 6
Order no.	24 0344 80 00 00	24 0345 80 00 00	24 0346 80 00 00	24 0347 80 00 00	24 0348 80 00 00	24 0349 80 00 00
Suitable heaters	Hydronic (B/D 4/5 W SC) Complete package	Hydronic (B/D 4/5 W SC) Complete package	Hydronic 2, Hydronic M2 plus Universal IK	Hydronic 2, Hydronic M2 plus Universal IK	Hydronic 2, Hydronic M2 plus Universal IK	Hydronic 2, Hydronic M2 plus Universal IK
∅ water hose for vehicle	18 mm	20 mm	18 mm	20 mm	18 mm	20 mm
Type of water circuit	thermostatic (interior and engine pre-heating)	thermostatic (interior and engine pre-heating)	thermostatic (interior and engine pre-heating)	thermostatic (interior and engine pre-heating)	Interior or engine pre-heating	Interior or engine pre-heating

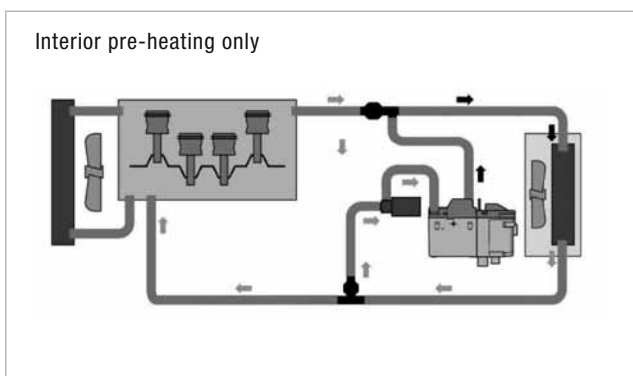
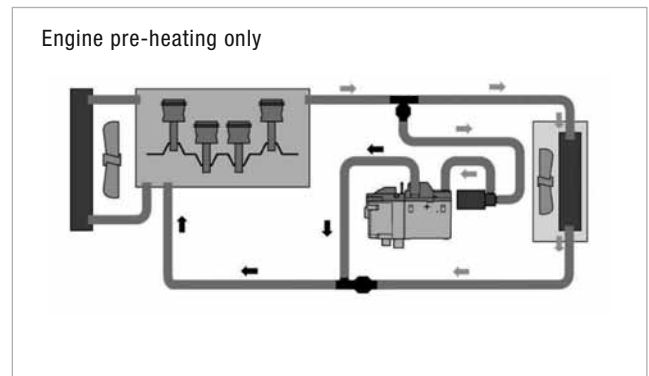
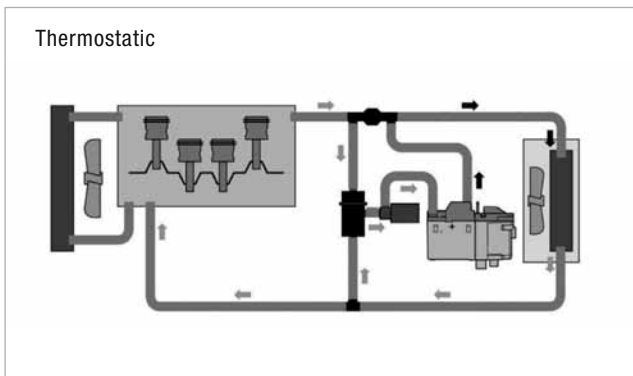

1

2

3

4

5

6

7

8

9

10

11

12

13

2 | HYDRONIC: OPTIONAL WATER CIRCUIT ON A HYDRONIC 2 COMFORT EXAMPLE

You can choose from a number of options when it comes to installing the new Hydronic 2 Comfort. The installation can be adapted to a wide variety of customer requirements by prioritizing the preferred type of heating required.

1. COMFORT INSTALLATION: PRIORITIZATION OF THE INTERIOR

This version is the most frequently used installation variant. Using the bypass, the interior and then the engine is heated (from around 67 °C).

2. SOLENOID VALVE INSTALLATION FOR SPECIFIC MARKETS: PRIORITIZATION OF THE ENGINE

This circuit option, which heats the engine first and then the interior (from around 67 °C) is available for specific markets which have a preference for rapidly heating the engine first.

3. CLASSIC PRE-HEATER INSTALLATION: IN-LINE WATER CIRCUIT

Like any other pre-heater, the Hydronic 2 Comfort can of course also be installed in-line in the water circuit. An additional dummy plug is required to do this. Ideal for installation jobs that need to be performed at short notice.

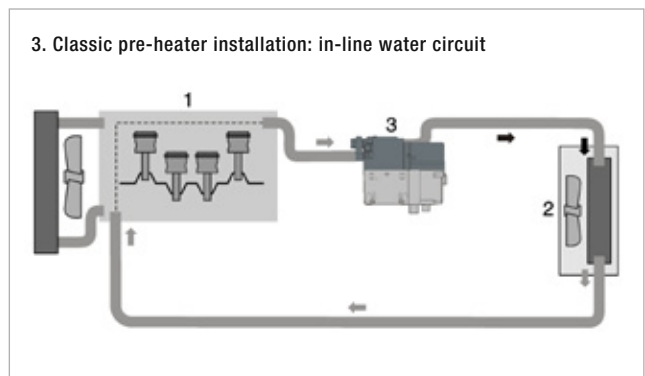
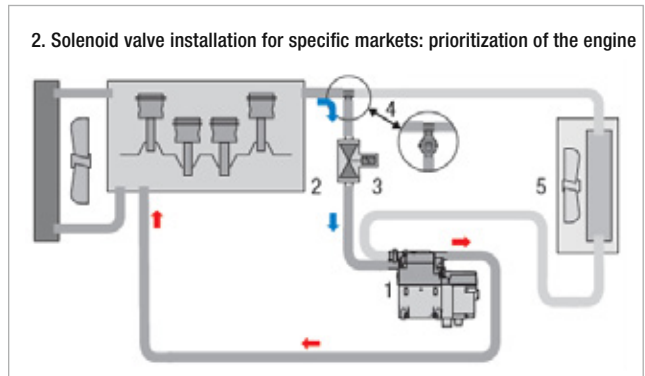
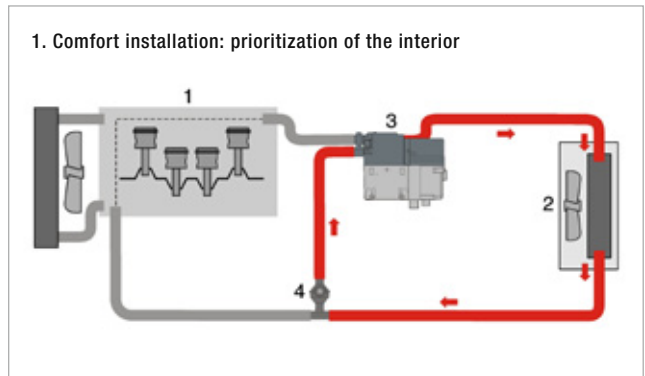

- 1. Engine
- 2. Convactor
- 3. Hydronic 2 Comfort
- 4. Thermostatic valve

1

2

3

4

5

6

7

8

9

10

11

12

13

2 | HYDRONIC: OPTIONAL ADD-ONS – FUEL SUPPLY

DIESEL:

- Hydronic 2 Economy with pressure-resistant metering pump:
- Advantage: easy to connect to the vehicle's fuel system, speeding up installation
- Prerequisite: Fuel pressure < 2 bar for diesel, no common rail diesel (due to fuel temperature), no check valve on tank connection, return line ends just above tank floor

Please note! The following versions of the Hydronic 2 Economy include the pressure-resistant metering pump:

D4S 12 V: 25 2558 05 00 00

D5S 12 V: 25 2557 05 00 00

GASOLINE:

- Gasoline applications with a pressure of > 0.2 bar also require the pressure reducer

Please note! For fuel lines pressurized at 2.0 bar to max. 4.0 bar, use the pressure reducer (order no. 22 1000 20 08 00) or a separate tank connection.

Fuel is extracted via a T-piece in the fuel return pipe from the engine to the tank cover

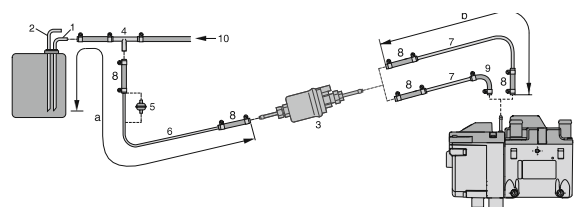

- | | | |
|---|--|---|
| 1. Fuel return line from vehicle tank cover | 5. Fuel filter – only required for contaminated fuel | 9. Elbow, 105° |
| 2. Fuel supply line from vehicle tank cover | 6. Fuel hose, 4 x 1 (di = 2 mm, blue) | 10. From the heater to the engine |
| 3. Metering pump (pressure resistant up to 2.0 bar) identified with a green label | 7. Fuel hose, 4 x 1.25 (di = 1.5 mm, transparent) | Permissible suction-side line length:
a = max. 2 m
Pressure side:
b = max. 6 m |
| 4. T-piece | 8. Fuel hose, 3.5 x 3 (di = 3.5 mm) | |

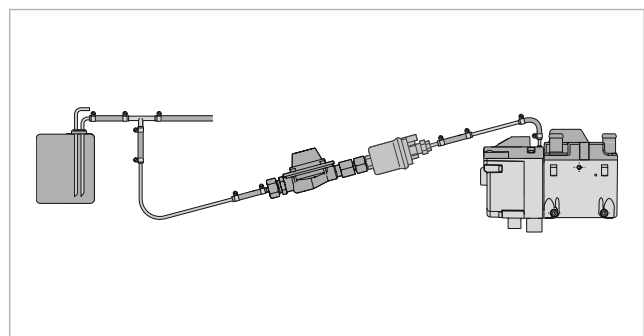

1

2

3

4

5

6

7

8

9

10

11

12

13

3 | AIRTRONIC: TECHNOLOGY

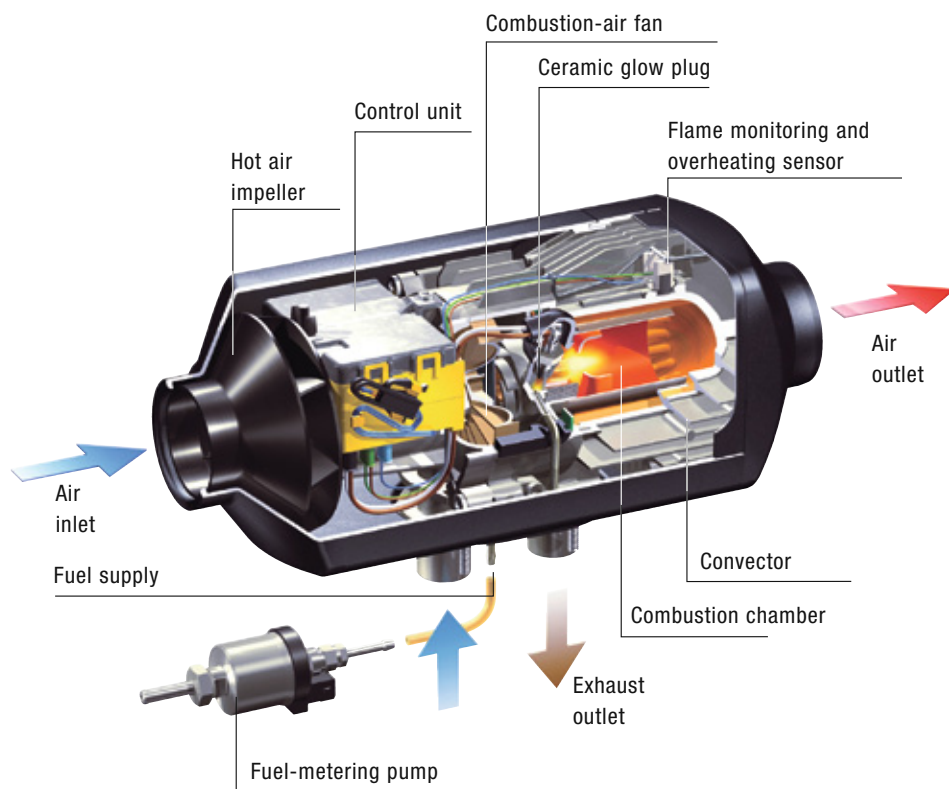

AIRTRONIC FUNCTIONS:

- Combustion air is conveyed to the combustion chamber by the fan motor and impeller.
- Fuel is drawn from the vehicle's tank.
- Fuel is conveyed to the combustion chamber by the metering pump.
- The glow element (filament glow plug from 5 kW) vaporizes this fuel as it enters the combustion chamber and creates a combustible fuel-air mix with the combustion air.
- The resulting flame formation switches off the glow element (or filament glow plug), transfers the heat to the heating air via the convector, and diverts exhaust gas via the exhaust muffler.
- The fan motor and heating-air impeller convey cool air to the heater, where it is warmed by the convector and then blown into the vehicle interior.

1

2

3

4

5

6

7

8

9

10

11

12

13

EBERSPÄCHER AIRTRONIC



Heater	Airtronic D2	Airtronic D2	Airtronic D3	Airtronic B4
Product package	Heater OR complete package	Heater OR complete package	Heater	Heater
Techn. designation	Airtronic (D2)	Airtronic (D2)	Airtronic M (D3)	Airtronic M (B4)
Order no. for heater	25 2069 05 00 00	25 2070 05 00 00	25 2317 05 00 00	20 1812 05 00 00
Order no. for complete package	25 2115 05 00 00	25 2116 05 00 00	—	—
Fuel	Diesel	Diesel	Diesel	Gasoline
Voltage	V 12	V 24	V 12	V 12
Heating medium	Air	Air	Air	Air
Control/heat settings	off/low/medium/high/power	off/low/medium/high/power	off/low/medium/high/power	off/low/medium/high/power
Heat output	W -/850/1,200/1,800/2,200	W -/850/1,200/1,800/2,200	W -/900/1,600/2,200/3,000	W -/1,300/2,100/3,200/3,800
Fuel consumption	l/h -/0.1/0.15/0.23/0.28	l/h -/0.1/0.15/0.23/0.28	l/h -/0.11/0.2/0.28/0.38	l/h -/0.18/0.29/0.46/0.54
Elec. power consumption, operation	W 5/8/12/22/34	W 5/8/12/22/34	W 5/7/10/16/24	W 5/9/15/29/40
Elec. power consumption, start	W 100	W 100	W 100	W 100
Air flow volume w/o backpressure	kg/h 13/40/60/90/105	kg/h 13/40/60/90/105	kg/h 24/60/90/120/150	kg/h 24/85/120/160/185
Lower voltage limit	V 10.2	V 21	V 10.5	V 10.5
Upper voltage limit	V 16	V 32	V 16	V 16
Interference suppression	Disturbance class 5 (DIN EN 55025)	Disturbance class 5 (DIN EN 55025)	Disturbance class 5 (DIN EN 55025)	Disturbance class 5 (DIN EN 55025)
Dimensions L x W x H	mm 310 x 115 x 122	mm 310 x 115 x 122	mm 376 x 140 x 150	mm 376 x 140 x 150
Weight empty	kg 2.7	kg 2.7	kg 4.5	kg 4.5
Ventilation mode	available	available	available	available

EBERSPÄCHER AIRTRONIC



Heater	Airtronic D4	Airtronic D4	Airtronic D4 Plus	Airtronic D4 Plus
Product package	Heater	Heater	Heater	Heater
Techn. designation	Airtronic M (D4)	Airtronic M (D4)	Airtronic M (D4 Plus)	Airtronic M (D4 Plus)
Order no. for heater	25 2113 05 00 00	25 2114 05 00 00	25 2484 05 00 00	25 2498 05 00 00
Fuel	Diesel	Diesel	Diesel	Diesel
Voltage	V 12	V 24	V 12	V 24
Heating medium	Air	Air	Air	Air
Control/heat settings	off/low/medium/high/power	off/low/medium/high/power	off/low/medium/high/power	off/low/medium/high/power
Heat output	W -/900/2,000/3,000/4,000	W -/900/2,000/3,000/4,000	W -/900/2,000/3,000/4,000	W -/900/2,000/3,000/4,000
Fuel consumption	l/h -/0.11/0.25/0.38/0.51	l/h -/0.11/0.25/0.38/0.51	l/h -/0.11/0.25/0.38/0.51	l/h -/0.11/0.25/0.38/0.51
Elec. power consumption, operation	W 5/7/13/24/40	W 5/7/13/24/40	W 5/7/16/30/55	W 5/7/16/30/55
Elec. power consumption, start	W 100	W 100	W 100	W 100
Air flow volume w/o backpressure	kg/h 24/60/110/150/185	kg/h 24/60/110/150/185	kg/h 22/55/100/140/175	kg/h 22/55/100/140/175
Lower voltage limit	V 10.5	V 21	V 10.5	V 21
Upper voltage limit	V 16	V 32	V 16	V 32
Interference suppression	Disturbance class 5 (DIN EN 55025)	Disturbance class 5 (DIN EN 55025)	Disturbance class 5 (DIN EN 55025)	Disturbance class 5 (DIN EN 55025)
Dimensions L x W x H	mm 376 x 140 x 150	mm 376 x 140 x 150	mm 376 x 140 x 150	mm 376 x 140 x 150
Weight empty	kg 4.5	kg 4.5	kg 4.5	kg 4.5
Ventilation mode	available	available	available	available

1

2

3

4

5

6

7

8

9

10

11

12

13

EBERSPÄCHER AIRTRONIC



Heater	Airtronic B5	Airtronic D5	Airtronic D5
Product package	Heater	Heater	Heater
Techn. designation	Airtronic L (B5)	Airtronic L (D5)	Airtronic L (D5)
Order no. for heater	20 1859 05 00 00	25 2361 05 00 00	25 2362 05 00 00
Fuel	Gasoline	Diesel	Diesel
Voltage	V 12	12	24
Heating medium	Air	Air	Air
Control/heat settings	low/medium/high/power	low/medium/high/power	low/medium/high/power
Heat output	W 2,000/2,700/4,800/5,500	1,600/2,700/4,800/5,500	1,600/2,700/4,800/5,500
Fuel consumption	l/h 0.27/0.37/0.65/0.75	0.2/0.34/0.58/0.66	0.2/0.34/0.58/0.66
Elec. power consumption, operation	W 15/30/80/85	25/35/80/85	25/35/80/85
Elec. power consumption, start	W 250	250	250
Air flow volume w/o backpressure	kg/h 125/180/275/280	155/190/275/280	155/190/275/280
Lower voltage limit	V 10.5	10.5	21
Upper voltage limit	V 16	16	32
Interference suppression	Disturbance class 5 (DIN EN 55025)	Disturbance class 5 (DIN EN 55025)	Disturbance class 5 (DIN EN 55025)
Dimensions L x W x H	mm 530 x 170 x 185	530 x 170 x 185	530 x 170 x 185
Weight empty	kg 9.3	9.3	9.3
Ventilation mode	available	available	available

EBERSPÄCHER AIRTRONIC



Heater	D8 LC	D8 LC
Product package	Heater	Heater
Techn. designation	8 L (D8 LC)	8 L (D8 LC)
Order no. for heater	25 1890 00 00 00	25 1891 00 00 00
Fuel	Diesel	Diesel
Voltage	V 12	24
Heating medium	Air	Air
Control/heat settings	low/high	low/high
Heat output	W 3,500/8,000	3,500/8,000
Fuel consumption	l/h 0.4/1.05	0.4/1.05
Elec. power consumption, operation	W 115	115
Elec. power consumption, start	W 330	380
Air flow volume w/o backpressure	kg/h 310	310
Lower voltage limit	V 10	20
Upper voltage limit	V 14	28
Interference suppression	Long-distance (additional measures possible)	Long-distance (additional measures possible)
Dimensions L x W x H	mm 653 x 260 x 250	653 x 260 x 250
Weight empty	kg 14	14
Ventilation mode	available	available

3 | AIRTRONIC: AIR-HEATER RANGE

The heating output information provided refers to heating the interior of a cold vehicle to around 20 °C in cold outside temperatures. If the heater only needs to maintain the existing temperature of the interior, less heating power is required. The heating outputs are only guide values. The exact heating requirement also depends on other environmental conditions (e.g. wind, materials, cabin walls, heating-air line, etc.).

GUIDE VALUES FOR REQUIRED HEATING OUTPUT

Example	Volume of interior	Outside temperature		
		< -15 °C	-15 °C to 0 °C	> 0 °C
Truck cabin	< 8 m³	4 kW	3 kW (2 kW)*	2 kW
Small bus	8–12 m³	5 kW (4 kW)*	4 kW (3 kW)*	2 kW
Motorhome/van	12–20 m³	8 kW	6 kW (5 kW)*	4 kW
Yacht/boat	> 20 m³	see documentation: Marine catalog		

* Values (referring to heat-insulated cabins/vehicles)

RANGE OF DEVICES AND THEIR RESPECTIVE ADVANTAGES:

- **Airtronic D2:** the smallest air heater on the market, advantageous in cramped installation spaces.
- **Airtronic D4:** output 4,000 W, air ducting 90 mm, for vans and suitably sized trucks; offers the advantage of high power within a reasonable installation space, wide-ranging application, from 900 W (gasoline 1,300 W) to 4,000 W.
- **Airtronic D3:** in well insulated vehicles, 3,000 W, 90 mm air ducting, energy-saving benefits of 7–24 W which makes it quiet and fuel-efficient, wide-ranging application 900–3,000 W.
- **Airtronic D4 Plus:** as a replacement device for the LC and LC compact due to its 75 mm air line, generally for longer 75 mm air lines; advantage of higher air flow with 75 mm, meets many ambulance standards.

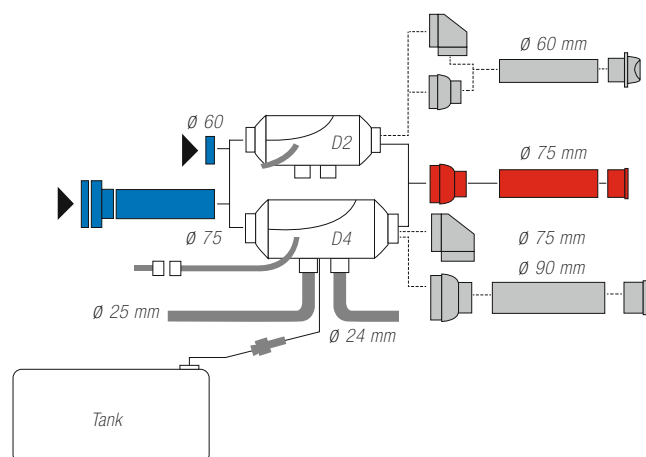

- 1
- 2
- 3
- 4
- 5
- 6
- 7
- 8
- 9
- 10
- 11
- 12
- 13

3 | AIRTRONIC: AIR-HEATER RANGE

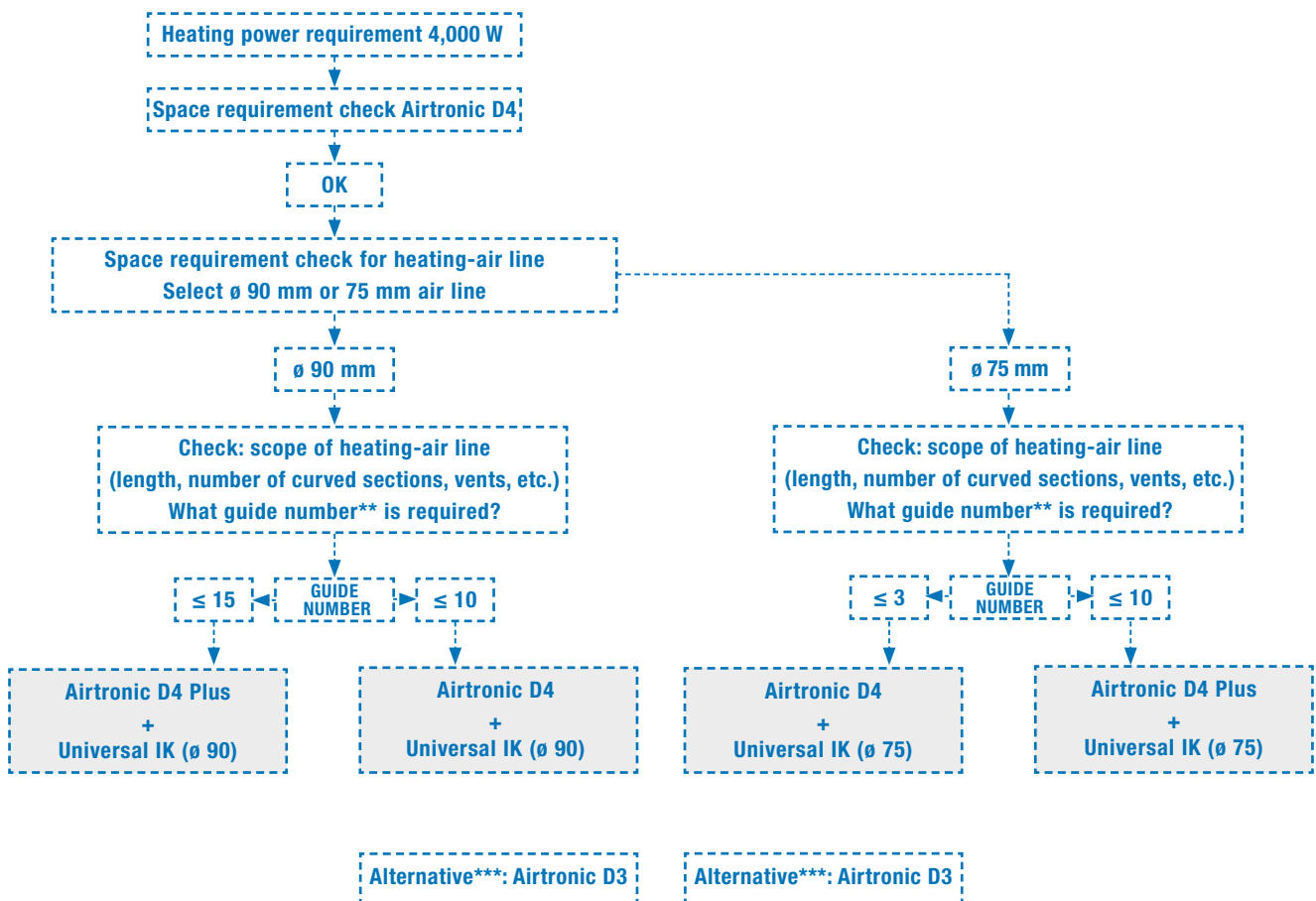

- 1
- 2
- 3
- 4
- 5
- 6
- 7
- 8
- 9
- 10
- 11
- 12
- 13

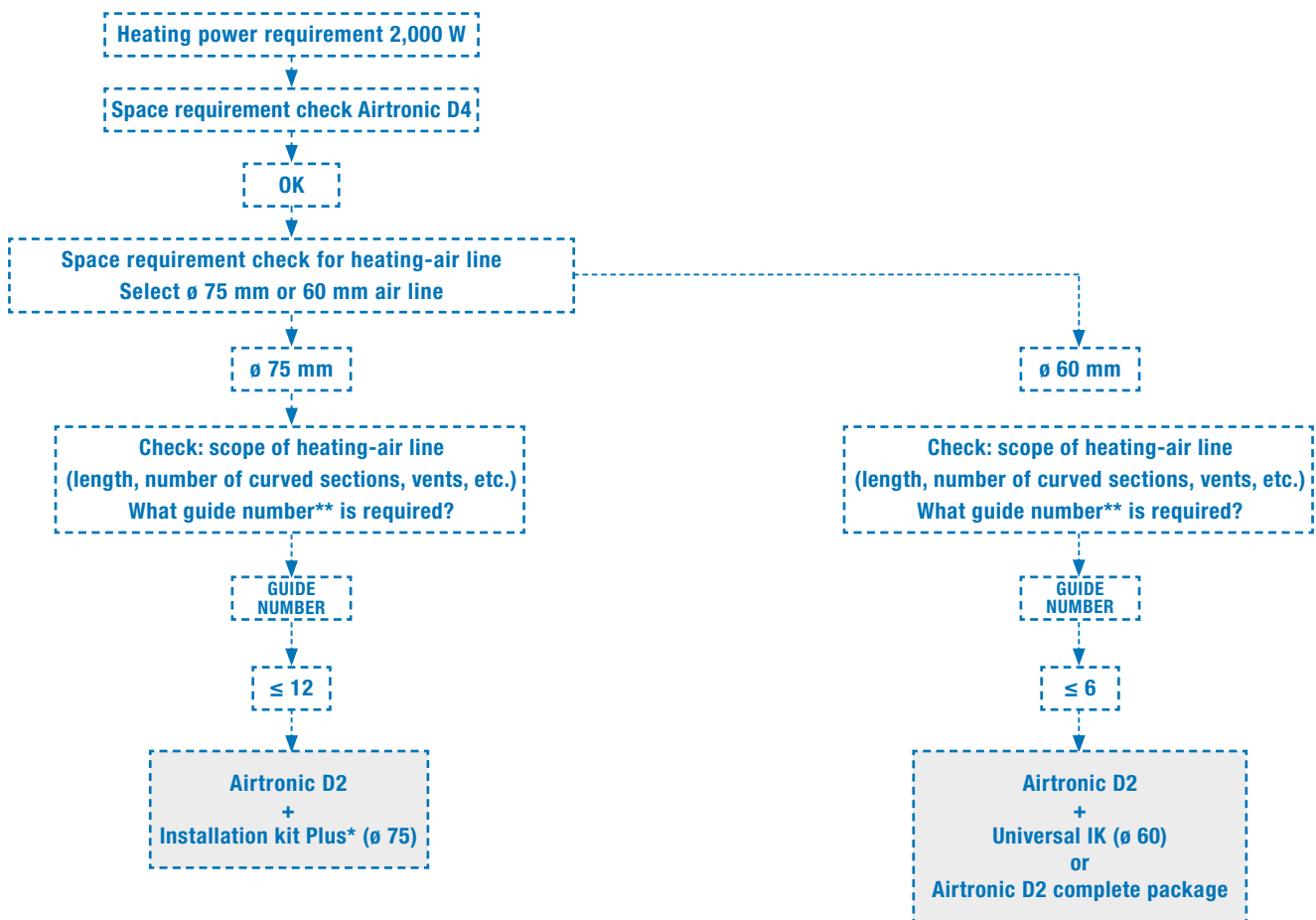

- 1
- 2
- 3
- 4
- 5
- 6
- 7
- 8
- 9
- 10
- 11
- 12
- 13

* Installation kit Plus = expanded product package

** Guide number: each component of the heating-air line (air hose, curved sections, vents, etc.) has a line guide number. The sum of these line guide numbers must not be greater than the guide number for the heater, otherwise the heater could malfunction – e.g. overheating. The higher the guide number for the heater, the more heating-air line components may be connected. Please refer to Eberspächer's Accessories catalog for a detailed explanation of guide numbers.

*** Airtronic D3 option: lower heating power (3,000 W) and therefore lower power consumption + and quieter operation => e.g. for well-insulated cabins

3 | AIRTRONIC: INSTALLATION KITS

GENERAL INFORMATION ON HEATING-AIR LINES:

Heating-air lines can also be mounted onto the heater. Each part has a line guide number which indicates the reduction in the heating-air throughput. In order to give you the opportunity to check that the installation you have planned does not reduce the heating-air throughput to an inadmissible level, we have calculated a heater guide number for each heater and a line guide number for each heating-air line; see information in the guide number tables:

0 = no temperature increase,
 – = no line guide number.

The total of the line guide numbers of the heating-air lines connected to the heater must not be greater than the heater guide number, as otherwise the vent temperature would be inadmissibly high, the heat distribution would be uneven and the overheating sensor would respond. If the total of the line guide numbers is greater than the heater guide number, the total can be reduced by selecting a larger diameter for the air lines or switching from a one-channel to a two-channel system.

1-channel means:

One heating-air channel leads to or from the heater. The line guide numbers under “1-channel” apply.

2-channel means:

After the heater, the heating-air line divides into two channels. Up until this branch, the line guide numbers specified under “1-channel” apply, from the branch onwards the line guide numbers under “2-channel” apply. Please refer to the notes on air lines and how to calculate the sum of air line guide numbers, page 42 onwards.

When using a two-channel heating-air line or with multiple air vents, at least one of the channels must be permanently open.

The branch that can be closed must not be taken into account when calculating the total of the line guide numbers.

RULE OF THUMB:

Double cross-section or two lines the same, routed in parallel = 1/4 of the guide number.

Example:

Hose \varnothing 60 mm

Cross-section A = 19.6 cm², guide number 1.0

Hose \varnothing 75,

Cross-section A = 44.2 cm², guide number 0.25

With smooth welded pipes, the line guide number is only half that of the flexible hose with the same diameter (i.e. double pipe length).

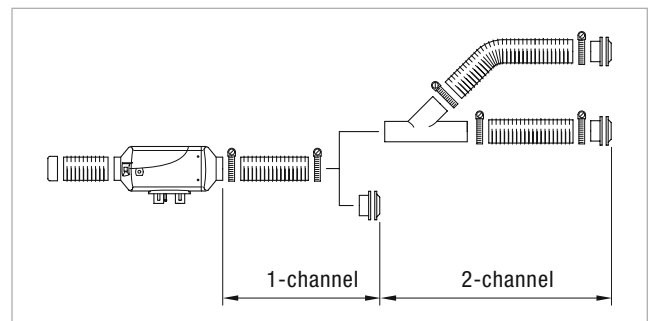

EXAMPLE CALCULATION OF A HEATING-AIR LINE:

Airtronic: Heater guide no = 6

NO.	DESCRIPTION	LINE GUIDE NUMBER
1	Protective grille	1.7
2	Connectors ø 60	1.7
3	Flex. pipe ø 60, 0.3 m long	0.3
4	Flex. pipe ø 60, 1.0 m long	1.0
5	Straight air scoop, ø 60	0
6	1 x 90° elbow, flex. pipe	1.2
7	Rotatable air vent	1.4
Total of the line guide numbers		5.6

Total of line guide numbers, 5.6, does not exceed the heater guide number 6, so the installation is admissible.

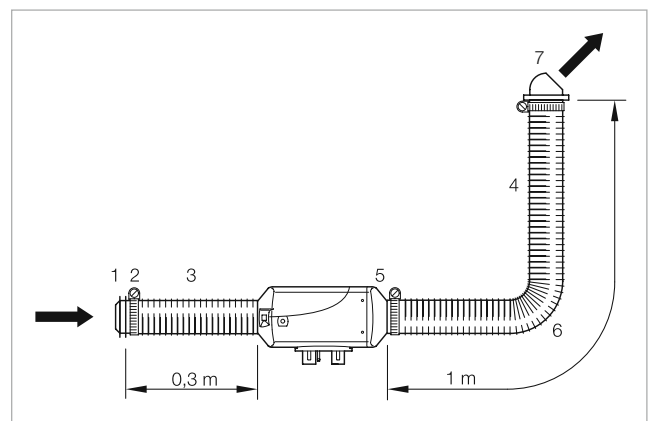

HEATER GUIDE NUMBERS:

HEATER	GUIDE NUMBER
Airtronic D2 with scoop 60	6
Airtronic D2 with scoop 75	12
Airtronic D3/D4/B4 with scoop 75	3
Airtronic D2 with scoop 90	10
Airtronic D4 Plus with scoop 75 (air-recirculation mode)	8
Airtronic D4 Plus with scoop 75 (fresh-air mode)	10
Airtronic D4 Plus with scoop 90	15

1

2

3

4

5

6

7

8

9

10

11

12

13

3 | AIRTRONIC: UNIVERSAL INSTALLATION KIT

Air heaters	Heater	Complete package
Airtronic D2, 12 V	25 2069 05 0000	25 2675 05 0000
Airtronic D2, 24 V	25 2070 05 0000	25 2676 05 0000
Airtronic D3, 12 V	25 2317 05 0000	
Airtronic B4, 12 V	20 1812 05 0000	
Airtronic D4, 12 V	25 2113 05 0000	
Airtronic D4, 24 V	25 2114 05 0000	
Airtronic D4 Plus, 12 V	25 2484 05 0000	
Airtronic D4 Plus, 24 V	25 2498 05 0000	

UNIVERSAL IK	Air scoop ø 60 mm Heater guide number 6	Air scoop ø 90 mm Heater guide number 10	Air scoop ø 90 mm Heater guide number 15	Air scoop ø 75 mm Heater guide number 3	Air scoop ø 75 mm Heater guide number 8, air- recirculation mode Heater guide number 8, fresh-air mode
Airtronic D2, 12 V	25 2069 80 0000				
Airtronic D2, 24 V	25 2069 80 0000				
Airtronic D3, 12 V		25 2113 80 0000		25 2484 80 0000	
Airtronic B4, 12 V		25 2113 80 0000		25 2484 80 0000	
Airtronic D4, 12 V		25 2113 80 0000		25 2484 80 0000	
Airtronic D4, 24 V		25 2113 80 0000		25 2484 80 0000	
Airtronic D4 Plus, 12 V			25 2113 80 0000		25 2484 80 0000
Airtronic D4 Plus, 24 V			25 2113 80 0000		25 2484 80 0000

PLEASE NOTE:

- See page 50 for control elements
- Parts with no image number are small parts which are bagged.
- If the installation requires additional parts, see page 74.
- For notes on heater guide numbers see pages 35 and 42.

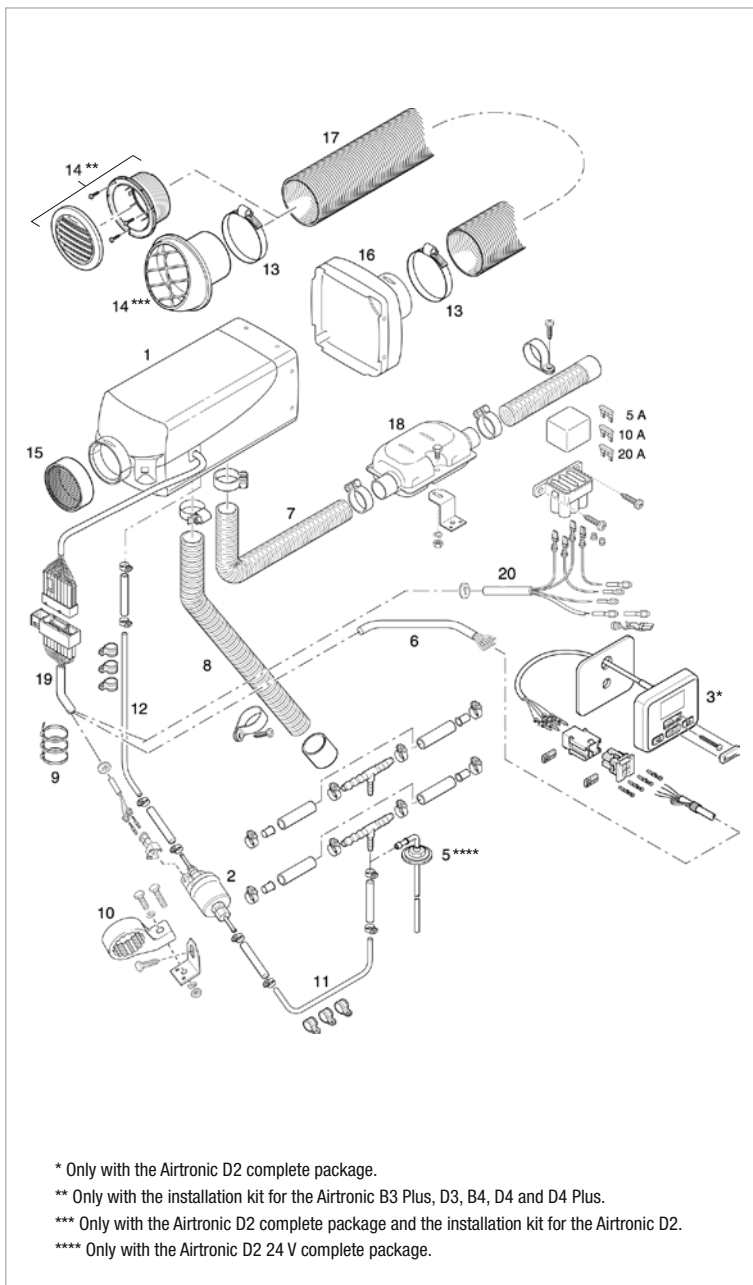

HEATER – PRODUCT PACKAGE:

1	Airtronic heater
2	Metering pump

COMPLETE PACKAGE – PRODUCT PACKAGE:

1	Airtronic heater
2	Metering pump
-	Installation kit with ø 60 mm air scoop
3	EasyStart Select
5	Fuel tank extractor – only with complete package 25 2676 05 0000

UNIVERSAL INSTALLATION KIT – PRODUCT PACKAGE:

6	Cable harness, operation
7	Flexible exhaust pipe
8	Combustion-air hose
9	Cable tie
10	Mounting bracket, metering pump
11	Pipe, 6 x 2
12	Pipe, 4 x 1.25
13	Hose clip, 2x
14	Rotatable air vent
15	Grille
16	Scoop
17	Flexible hose
18	Exhaust muffler
19	Cable harness, heater
20	Cable harness, Plus/Minus

- 1
- 2
- 3
- 4
- 5
- 6
- 7
- 8
- 9
- 10
- 11
- 12
- 13

3 | AIRTRONIC: INSTALLATION KIT “PLUS”

“PLUS” INSTALLATION KITS ARE IDEAL FOR INSTALLATIONS IN MOTORHOMES AND BOATS.

INSTALLATION KIT “PLUS”	Air scoop ø 75 mm Heater guide number 12
Airtronic D2, 12 V	25 2069 81 0000
Airtronic D2, 24 V	25 2069 81 0000

1

2

3

4

5

6

7

8

9

10

11

12

13

PLEASE NOTE:

- See page 50 for control elements
- Parts with no image number are small parts which are bagged.
- If the installation requires additional parts, see page 74.
- For notes on heater guide numbers see pages 35 and 42.

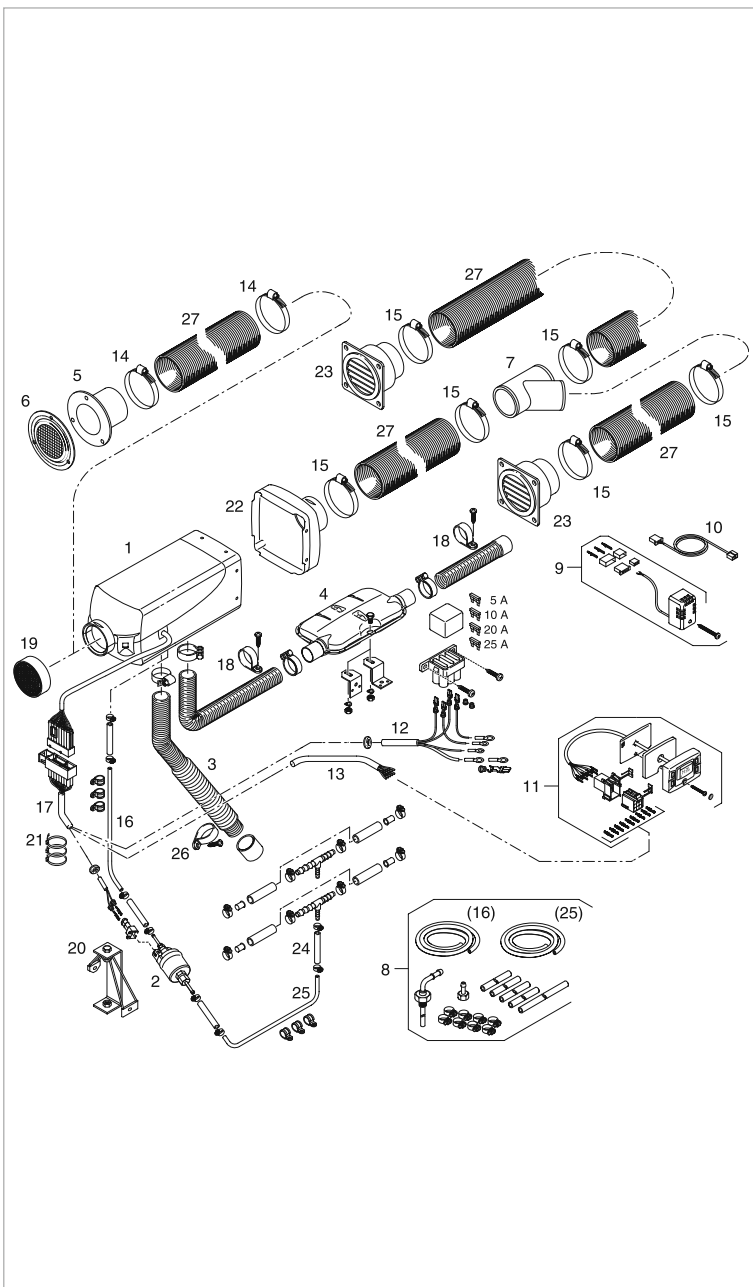

HEATER – PRODUCT PACKAGE:

1	Airtronic heater
2	Metering pump

INSTALLATION KIT “PLUS” – PRODUCT PACKAGE:

3	Combustion-air intake muffler
4	Exhaust muffler
5	Hose fitting
6	Grille
7	Y-junction
8	Kit to tank connector
9	Temperature control sensor
10	Cable harness for temperature control sensor
11	EasyStart T timer
12	Cable harness, Plus/Minus
13	Cable harness, operation
14	Hose clip (2x)
15	Hose clip (6x)
16	Pipe, 4 x 1.25 (included with Item 8)
17	Cable harness, heater
18	Flexible exhaust pipe
19	Grille
20	Mounting bracket, metering pump
21	Cable tie (2x)
22	Scoop
23	Air vent (2x)
24	Adapter \varnothing 6/4
25	Pipe, 4 x 1 (included with Item 8)
26	Pipe clip, \varnothing 50 mm

NOT IN PRODUCT PACKAGE:

27	Flexible pipe for heating-air line
----	------------------------------------

- 1
- 2
- 3
- 4
- 5
- 6
- 7
- 8
- 9
- 10
- 11
- 12
- 13

3 | AIRTRONIC: INSTALLATION PARTS

Air heaters	Heater	Universal IK
Airtronic L – B5, 12 V	20 1859 05 0000	25 2361 80 0000
Airtronic L – D5, 12 V	25 2361 05 0000	25 2361 80 0000
Airtronic L – D5, 24 V	25 2362 05 0000	25 2361 80 0000

PLEASE NOTE:

- See page 50 for control elements
- Parts with no image number are small parts which are bagged.
- If the installation requires additional parts, see page 74.

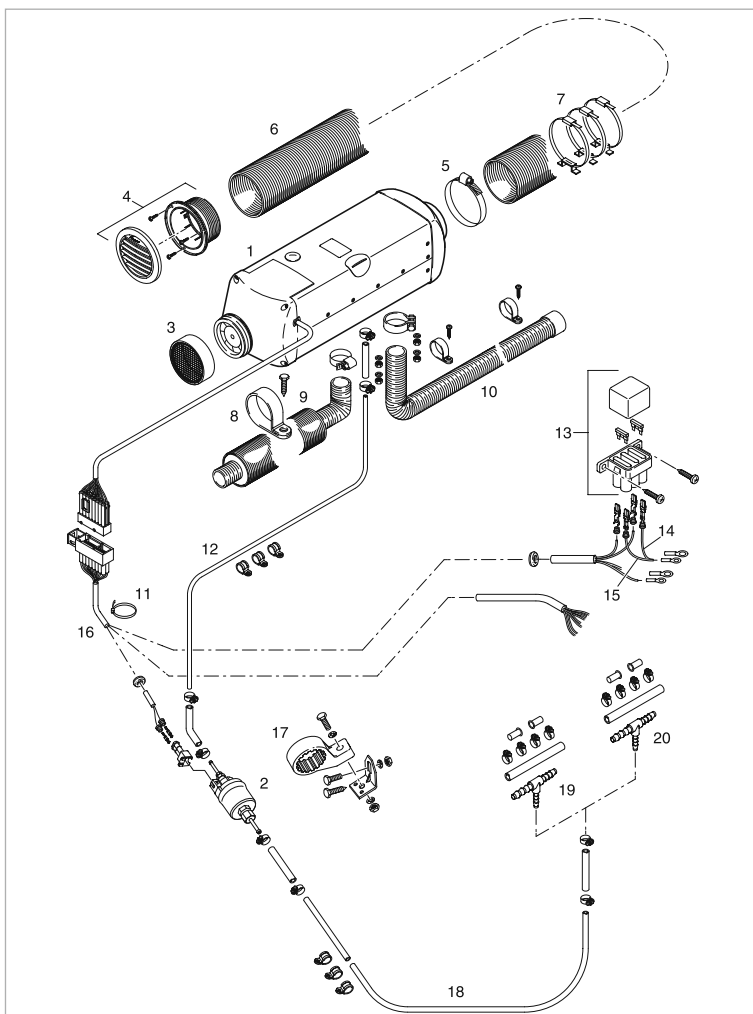

HEATER – PRODUCT PACKAGE:

- | | |
|---|------------------|
| 1 | Airtronic heater |
| 2 | Metering pump |

UNIVERSAL INSTALLATION KIT – PRODUCT PACKAGE:

- | | |
|----|---------------------------------|
| 3 | Grille, ø 90 mm |
| 4 | Flat vent, 30° |
| 5 | Hose clip, ø 90 mm–110 mm (2x) |
| 6 | Flexible hose ø 90 mm |
| 7 | Bracket (3x) |
| 8 | Pipe clip, ø 50 mm |
| 9 | Intake muffler |
| 10 | Flexible exhaust pipe ø 24 mm |
| 11 | Cable tie 200 (2 x 10) |
| 12 | Fuel pipe, 4 x 1.25, 7.5 m long |
| 13 | Fuse holder |
| 14 | Plus cable, 1 ² rt |
| 15 | Plus cable, 4 ² rt |
| 16 | Cable harness |
| 17 | Mounting bracket, metering pump |
| 18 | Fuel pipe, 6 x 2, 1.5 m long |
| 19 | Hose connector 8/6/8 |
| 20 | Hose connector 10/6/10 |

1

2

3

4

5

6

7

8

9

10

11

12

13

Air heaters	Heater
D8 LC, 12 V	25 1890 00 0000
D8 LC, 24 V	25 1891 00 0000

PLEASE NOTE:

- See page 50 for control elements
- Parts with no image number are small parts which are bagged.
- If the installation requires additional parts, see page 74.

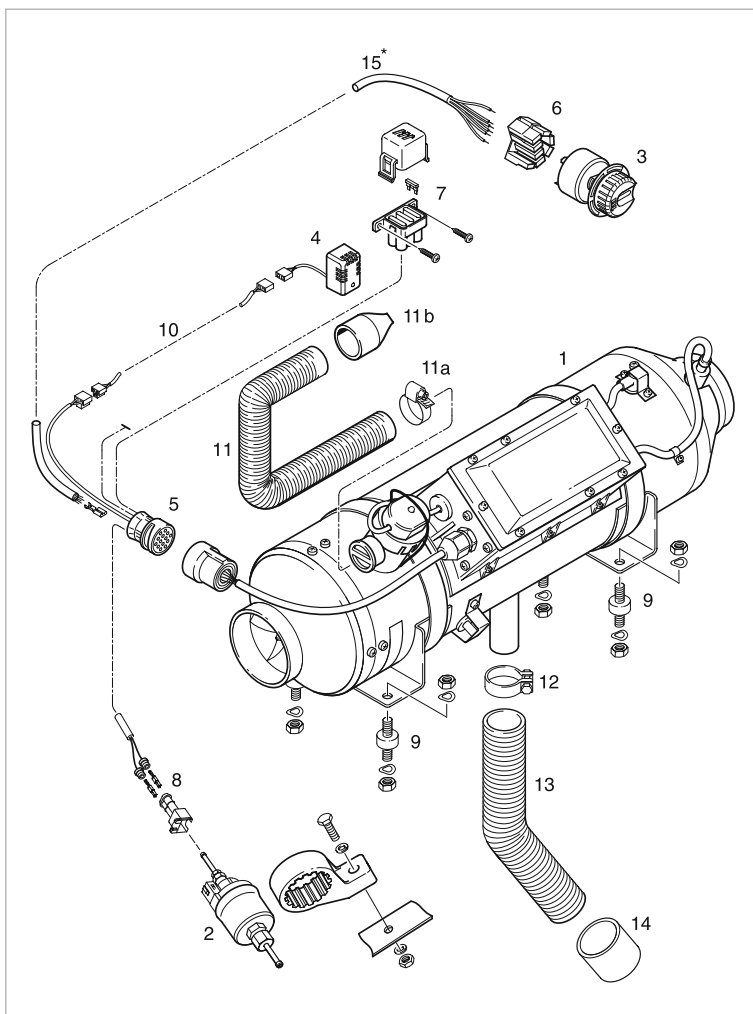

HEATER – PRODUCT PACKAGE:

1	Heater, pre-mounted
2	Metering pump with integrated fuel filter and mounting bracket
3	Control unit
4	Temperature sensor, external
5	Cable harness with connection parts
6	Bushing connector housing with connection parts
7	Blade fuse with fuse holder
8	Bushing connector housing with bushing connectors and seals (2x)
9	Rubber-metal buffer with fastening parts (4x)

NOT INCLUDED IN PRODUCT PACKAGE:

10	Cable harness, temperature sensor	25 1482 89 4000
11	Combustion-air hose	10 2114 25 0000
11a	Hose clip	10 2067 03 2050
11b	End sleeve for combustion-air hose	25 1480 89 0400
12	Pipe clip for flex. exhaust pipe LW42	152 05 005
13	Flexible exhaust pipe LW42	360 61 381
14	End sleeve for flex. exhaust pipe LW42	22 1000 40 0200
-	Exhaust pipe (rigid)	047 05 044
15*	Cable harness, control unit	

* Self-assembly with the 5 m cable harness (Order no. 22 1000 30 0300). Cut the existing connectors off the cable harness. Prepare the cable strands for the bushing connectors and fit them. The bushing connectors are included in the product package. Connect the cable harness to the cable harness connector (5) and to the bushing connector housing of the control unit (6) following the circuit diagrams at the end of the documentation.

1

2

3

4

5

6

7

8

9

10

11

12

13

3 | AIRTRONIC: GUIDE NUMBERS

AIRTRONIC

Heater number **6** – with \varnothing 60 air scoop

Heater number **12** – with \varnothing 75 air scoop

The drawing shows the application options for the main air lines.

There are no installation examples.

PLEASE NOTE:

For an explanation of single and dual-channel heating-air lines, see page 36.

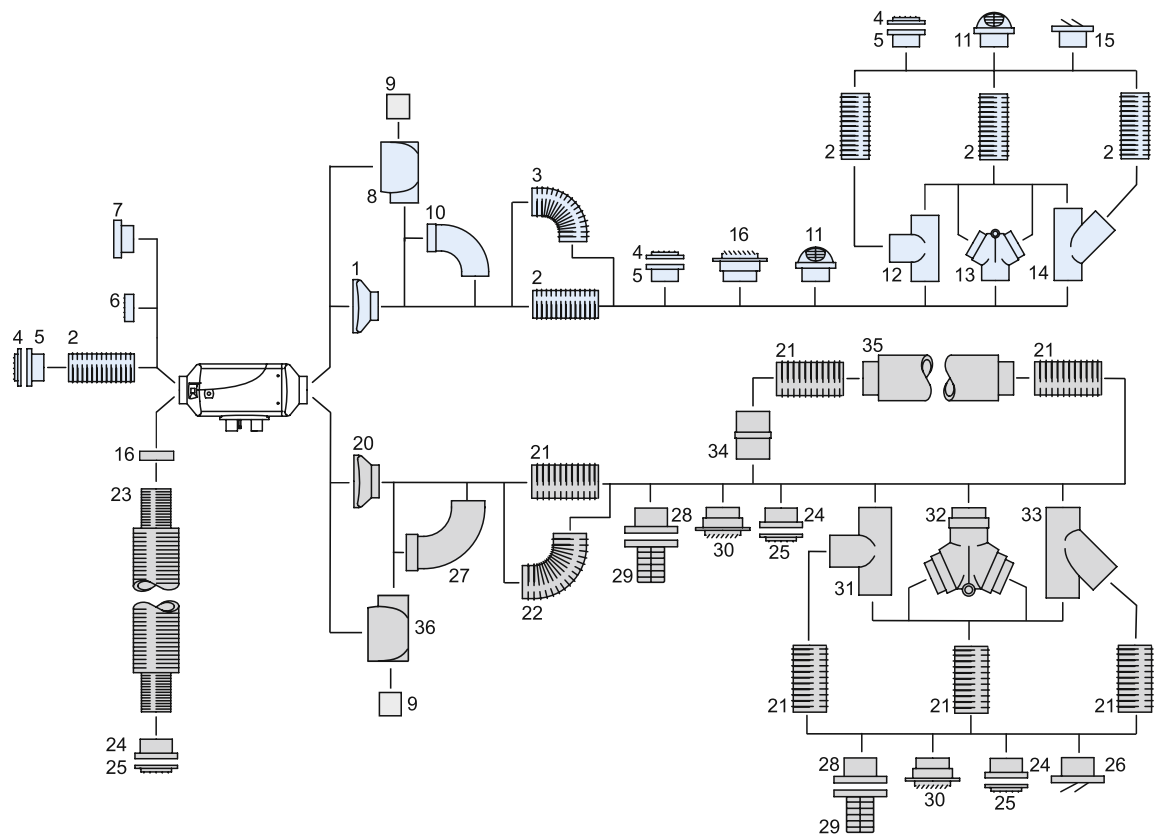

- = \varnothing 50 mm
- = \varnothing 60 mm
- = \varnothing 75 mm

- 1
- 2
- 3
- 4
- 5
- 6
- 7
- 8
- 9
- 10
- 11
- 12
- 13

NO.	NAME (DIMENSIONS IN MM)	LINE GUIDE NUMBER 1-CHANNEL	LINE GUIDE NUMBER 2-CHANNEL	SEE SERIES NO. AIR LINES
Heating-air line with ø 60 scoop (heater guide number 6)				
1	Scoop, ø 60	0	0	21
2	Flex. pipe, ø 60 per m	1.0	0.25	1
3	90° elbow, flexible pipe	0.2	–	–
4	Grille	0.5	0.1	13.1
5	Plastic hose fitting, ø 60	0	0	18
6	Heater grille, ø 60	0	–	17
7	Air filter, ø 60	1.6	–	5
8	Ball-shaped scoop, ø 60	4.8	–	32
9	ø 50 connection fitting for ø 60 ø 75 ball-shaped scoops	4.5	–	31
10	Pipe elbow, 90° ø 60	4	–	33
11	Rotatable air vents, ø 60	3.2	0.8	10.1
12	T-junction	1.4	0.25	35
13	Butterfly valve ø 60/60/60 with "right/left" flap position	–	0.6	40
14	Y-junction	–	1	43
15	Closable round nozzle, ø 60	–	–	12.1
16	Rotatable air vents, ø 60	0.7	0.2	11.1
–	Symmetrical metal Y-junction ø 60/50/50	–	0.3	42
Heating-air line with ø 75 scoop (heater guide number 12)				
20	Scoop, ø 75	0	0	21
21	Flex. pipe ø 75 per m	1	0.25	1
22	90° elbow, flex. pipe, ø 75	0.2	–	1
23	Intake muffler, ø 75	0.7	–	4
24	Metal hose fitting, ø 75	0	0	20
25	Plastic grille, ø 75	0.6	0.1	13.1
26	Upright vent, 30° ø 75	0.5	0.15	10
27	Pipe elbow, 90° ø 75	4.5	–	33
28	Plastic hose fitting, ø 75	0	0	16
29	Upright vent, 90° ø 75	0.8	0.15	14
30	Rotatable air vents, ø 75	0.6	0.2	11.1
31	T-junction ø 75/75/75	–	0.8	35
32	Butterfly valve ø 75/75/75 Flap position "left/right" Flap position "center"	–	1.2	40
33	Y-junction ø 75/75/75	–	0.6	43
34	Hose connector fitting, ø 75	0.5	0.1	44
35	Muffler, ø 75	0.6	–	3
36	Ball-shaped scoop, ø 75	6	–	32
New	Flat vent, 0° with ø 75 fitting	0.5	0.15	13
New	Flat vent, 30° with ø 75 fitting	0.5	0.15	11
–	Symmetrical metal Y-junction ø 75/50/50	–	0.9	42.1
–	Symmetrical plastic Y-junction ø 75/60/60	–	0.8	42
–	Adapter, ø 60–75	3.2	–	45

1

2

3

4

5

6

7

8

9

10

11

12

13

3 | AIRTRONIC: GUIDE NUMBERS

AIRTRONIC M

Heater number **3** – with \varnothing 75 air scoop

Heater number **10** – with \varnothing 90 air scoop

The drawing shows the application options for the main air lines.
There are no installation examples.

* Heater guide numbers for the Airtronic D4 Plus are different,
see page 38.

PLEASE NOTE:

For an explanation of one-channel and two-channel heating-air lines, see page 36.

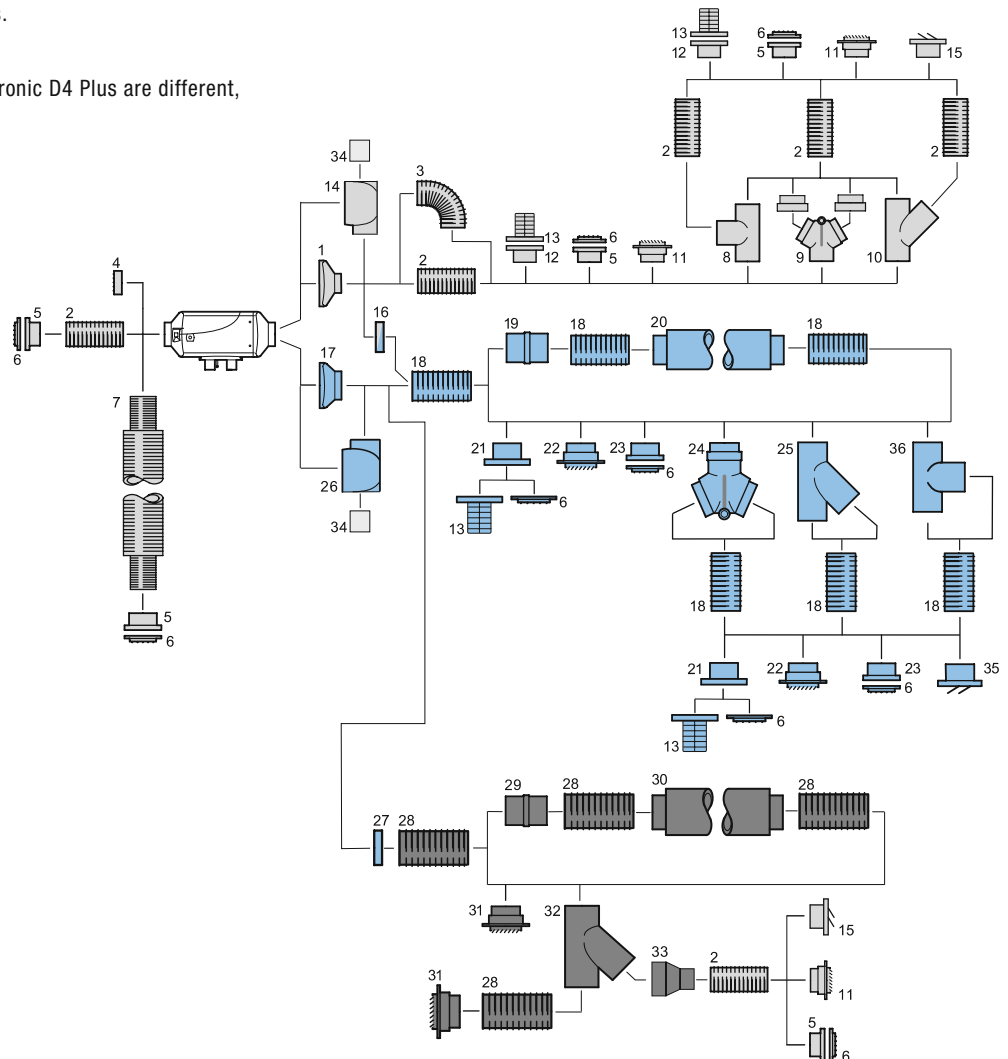

- = \varnothing 50 mm
- = \varnothing 75 mm
- = \varnothing 90 mm
- = \varnothing 100 mm

- 1
- 2
- 3
- 4
- 5
- 6
- 7
- 8
- 9
- 10
- 11
- 12
- 13

NO.	NAME (DIMENSIONS IN MM)	LINE GUIDE NUMBER 1-CHANNEL		LINE GUIDE NUMBER 2-CHANNEL		SEE SERIES NO. AIR LINES
		ø 75	ø 90	ø 75	ø 90	
	Heating-air line with ø 75 scoop (heater number 3)					
1	Scoop, ø 75	0	–	–	–	21
2	Flex. pipe ø 75 per m	1	–	0.25	–	1
3	90° elbow, flexible pipe, ø 75	0.2	–	–	–	1
4	Nickel-plated heater grille	0.4	–	0.1	–	13.1
5	Metal hose fitting, ø 75	0.0	–	0.0	–	20
6	Grille, ø 75	2.0	–	–	–	17
7	Intake muffler, ø 75	0.8	–	–	–	4
8	T-junction, ø 75	–	–	0.5	–	35
9	Butterfly valve, ø 75/75/75	–	–	1.8	–	40
10	Plastic Y-junction ø 75/75/75	–	–	0.6	–	43
11	Rotatable vent, 30°	0.8	–	0.2	–	11.1
12	Fitting, ø 75	0	–	0	–	16
13	Rotatable vent, 90° ø 75	1.1	–	0.3	–	14
14	Ball-shaped scoop, ø 75	2.0	–	–	–	32
15	Closable vent	–	–	–	–	12
16	Ring, ø 75/90	0.5	–	–	–	34
New	Symmetrical plastic Y-junction ø 75/50/50	–	–	0.9	–	42
New	Flat vent, 0° with ø 75 fitting	0.4	–	0.1	–	13
New	Flat vent, 30° with ø 75 fitting	0.4	–	0.1	–	11
New	Flat vent, 30° with ø 75 fitting	0.6	–	0.2	–	10
–	Symmetrical metal Y-junction ø 75/50/50	–	–	1.2	–	42
–	Hose connector	0.5	–	0.1	–	44
	Heating-air line with ø 90 scoop (heater number 10)					
17	Scoop, ø 90	–	0	–	–	21
18	Flex. pipe ø 90 per m	–	1	–	0.25	1
19	Hose connector fitting, ø 90	–	0.5	–	0.1	44
20	Muffler, ø 90	–	0.7	–	–	3
21	Fitting, ø 90	–	0	–	0	16
22	Flat vent 30°	–	2.2	–	0.5	11.1
6	Nickel-plated grille	–	0.4	–	0.1	13.1
24	Butterfly valve, ø 90/90/90	–	1.2	–	–	40
25	Y-junction ø 90/90/90	–	–	–	0.3	43
26	Ball-shaped scoop, ø 90	–	5.0	–	–	32
27	Ring, ø 90/100	–	0	–	–	34
28	Flexible pipe, ø 100, per m	–	0.4	–	–	1
29	Hose connector fitting, ø 100	–	0.1	–	–	44
30	Muffler, ø 100	–	0.5	–	–	3
31	Rotatable adapter, ø 100	–	2.1	–	0.5	11.1
32	Y-junction ø 100/100/100	–	–	–	0.5	43
33	Adapter ø 75–100	–	–	–	0.8	45
34a	Connection fitting 50x ø 75	–	–	–	1.0	31
34b	Connection fitting 50x ø 90	–	–	–	2.5	31
35	Closable vent	–	–	–	–	12
36	T-junction, ø 90	–	–	–	0.6	35
New	Symmetrical plastic Y-junction ø 90/75/75	–	–	–	0.9	42
New	Symmetrical plastic Y-junction ø 90/60/60	–	–	–	2.1	42
New	New flat grille, 0° with ø 90 fitting	–	1.1	–	0.3	13
New	New flat grille, 30° with ø 90 fitting	–	2.0	–	0.4	11
New	New upright vent, 30° with ø 90 fitting	–	2.4	–	0.6	10
New	New upright vent, 90°	–	2.7	–	0.3	14
–	Adapter ø 75–90	–	3.3	–	–	45
–	T-junction, ø 100	–	–	–	0.4	35
–	90° elbow, flexible pipe, ø 75	0.1	–	–	–	1
–	Adapter ø 90–100	–	0.4	–	–	1

* Cannot be used with the Airtronic D4 Plus

1

2

3

4

5

6

7

8

9

10

11

12

13

3 | AIRTRONIC: GUIDE NUMBERS

AIRTRONIC L

Heater number **10**

The drawing shows the application options for the main air lines.
There are no installation examples.

PLEASE NOTE:

For an explanation of one-channel and two-channel heating-air lines, see page 36.

- 1
- 2
- 3
- 4
- 5
- 6
- 7
- 8
- 9
- 10
- 11
- 12
- 13

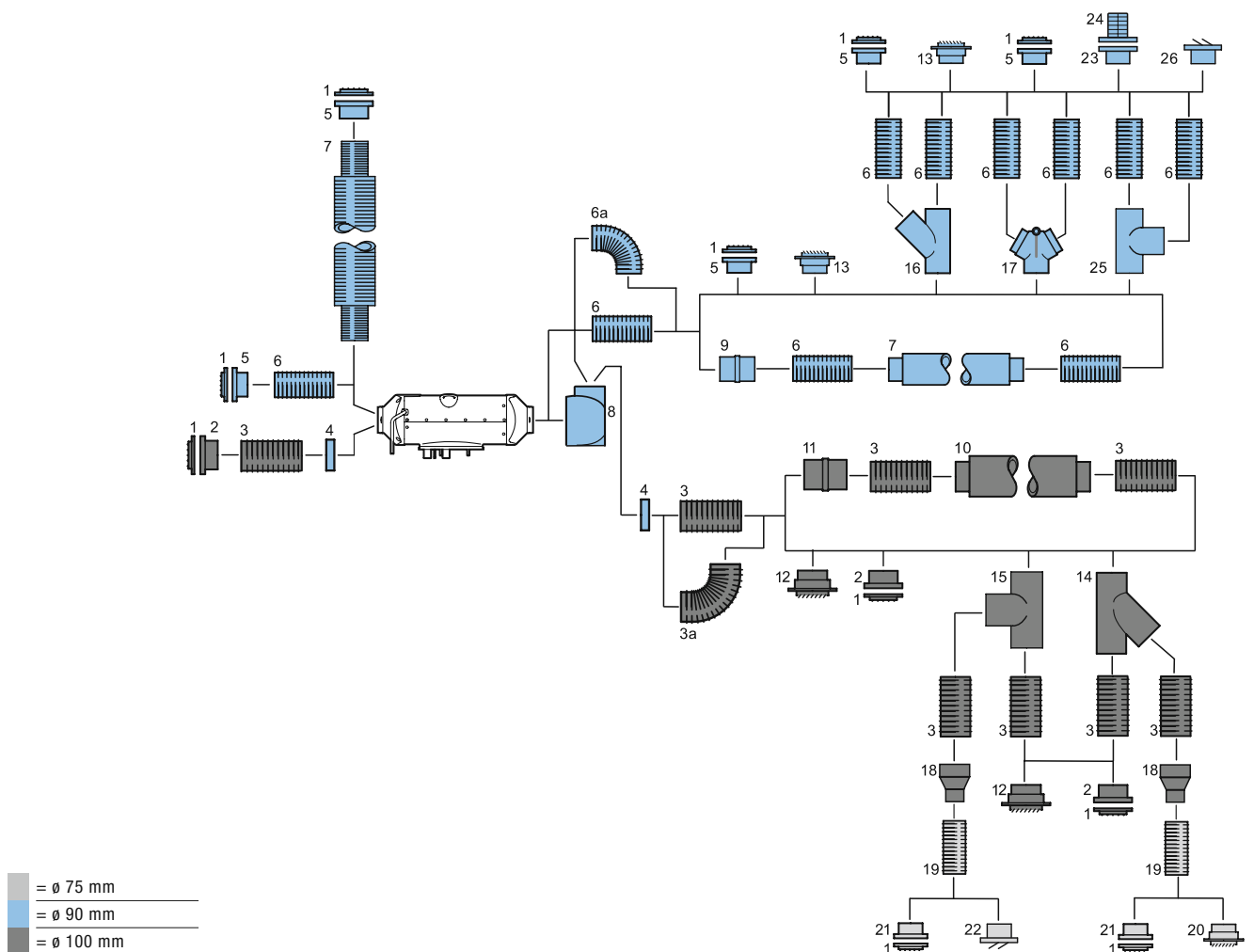

NO.	NAME (DIMENSIONS IN MM)	LINE GUIDE NUMBER 1-CHANNEL	LINE GUIDE NUMBER 2-CHANNEL	SEE SERIES NO. AIR LINES
Heating-air line with ø 90 scoop (heater number 10)				
1	Metal grille vent 90	0.6	0.2	13.1
2	Metal hose fitting, ø 90	0	0	19
3	Flexible pipe, ø 100, per m	0.6	0.2	1
3a	90° elbow, flexible pipe, ø 100	0.6	–	1
4	Adapter, ø 90/100 with grille	0	–	17
5	Metal hose fitting, ø 90	0	0	20
6	Flexible pipe, ø 90, per m	1	0.25	1
6a	90° elbow, flexible pipe, ø 90	0.2	–	1
7	Muffler, ø 90	0.8	–	3
8	Ball-shaped scoop, ø 90	8	–	22
9	Hose connector fitting, ø 90	0.5	0.1	46
10	Muffler, ø 100	0.5	–	3
11	Hose connector fitting, ø 100	0.4	0.1	44
12	Flat vent, ø 100, 30°	2	0.5	11.1
13	Rotatable adapter, ø 90	2	0.5	11.1
14	Y-junction ø 100/100/100	–	0.5	43
15	T-junction ø 100/100/100	–	0.5	35
16	Y-junction ø 90/90/90	–	0.6	43
17	Butterfly valve, ø 90/90/90	–	1.1	40
18	Adapter ø 75–100	3.2	–	45
19	Flexible pipe, ø 75, per m	4	1	1
20	Rotatable adapter, ø 75	–	1.25	11.1
21	Metal hose fitting, ø 75	0	0	21
22	Closable vent 75	–	–	12
23	Fitting, 90	0	0	16
24	Upright vent 90°	3	0.8	14
25	T-junction ø 90/90/90	–	0.6	35
26	Closable vent 90	–	–	12
New	Symmetrical plastic Y-junction ø 90/75/75	–	0.9	42
New	Flat vent, ø 90, 0°	1	0.2	13
New	Flat vent, ø 90, 30°	1.7	0.4	11
New	Upright vent, ø 90, 30°	2.3	0.6	10
New	Flat vent, 0° with ø 75 fitting	2.5	0.7	13
New	Flat vent, 30° with ø 75 fitting	2.7	0.8	11
New	Flat vent, 30° with ø 75 fitting	2.1	0.5	10
New	Flat vent, 90° with ø 75 fitting	4.7	1.2	14
–	Scoop, 90	0	0	–
–	90° elbow, flexible pipe, ø 75	1	0.25	1
–	Plastic heater grille, ø 90	2	–	17

* Item 4 – when using the ø 90/100 adapter, cut the grille

1

2

3

4

5

6

7

8

9

10

11

12

13

3 | AIRTRONIC: GUIDE NUMBERS

AIR HEATER 8 L

Heater number **8**

The drawing shows the application options for the main air lines.
There are no installation examples.

PLEASE NOTE:

For an explanation of one-channel and two-channel heating-air lines, see page 36.

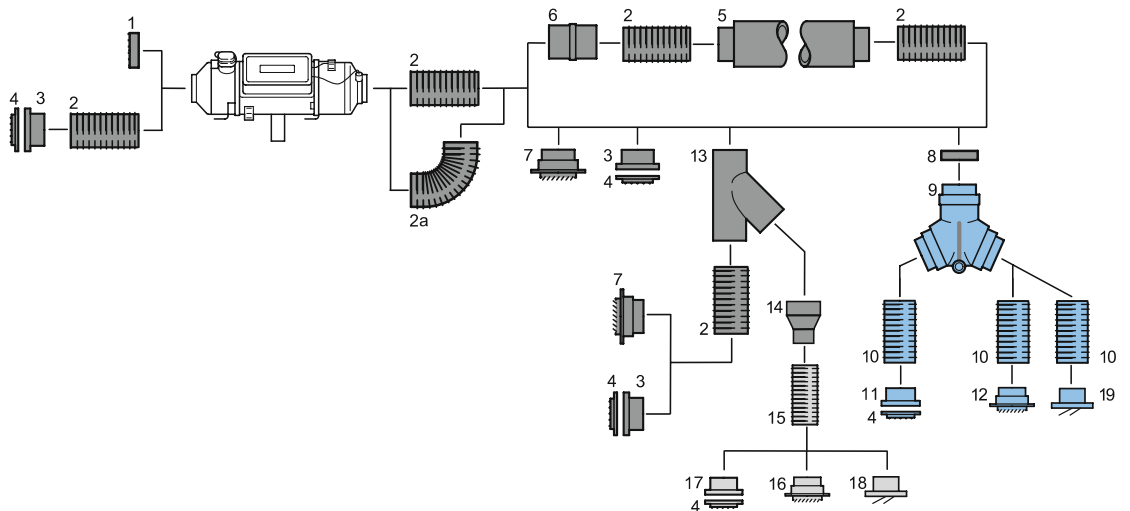

- = ø 75 mm
- = ø 90 mm
- = ø 100 mm

- 1
- 2
- 3
- 4
- 5
- 6
- 7
- 8
- 9
- 10
- 11
- 12
- 13

NO.	NAME (DIMENSIONS IN MM)	LINE GUIDE NUMBER 1-CHANNEL	LINE GUIDE NUMBER 2-CHANNEL	SEE SERIES NO. AIR LINES
Heating-air line with ø 100 scoop (heater number 8)				
1	Grille, ø 100	0.1	–	17
2	Flexible pipe, ø 100, per m	1	0.25	1
2a	90° elbow, flexible pipe, ø 100	0.5	0.15	1
3	Metal hose fitting, ø 100	0	0	19
4	Painted grille ø 100	1.8	0.1	13.1
4	Nickel-plated grille ø 100	1.8	0.1	13.1
5	Muffler, ø 100	1.1	0.25	3
6	Hose connector fitting, ø 100	0.5	0.1	44
7	Rotatable adapter, ø 100	5.5	1.2	11.1
9	Butterfly valve, ø 90/90/90	–	2.6	40
10	Flexible pipe, ø 90, per m	3	0.8	1
11	Metal fitting, ø 90	0	0	20
12	Rotatable adapter, ø 90	–	1.4	11.1
13	Y-junction, ø 100	–	0.4	43
14	Adapter ø 75–100	6.1	–	47
15	Flexible pipe, ø 75, per m	–	2	1
17	Fitting, ø 75	0	0	20
18	Closable vent 75	–	–	12
19	Closable vent 90	–	–	12
–	90° elbow, flexible pipe, ø 75	–	1.1	1
–	T-junction, ø 100	–	0.2	35
–	Adapter ø 90–100	1.4	–	44
New	Fitting, 75	0	0	16
New	Flat vent, 0° with ø 75 fitting	–	1.3	13
New	Flat vent, 30° with ø 75 fitting	–	1.5	11
New	New upright vent, 30° with ø 75 fitting	–	1.6	10
New	New upright vent, 90° with ø 75 fitting	–	1.8	14
New	Fitting, 90	0	0	16
New	Flat vent, 0° with ø 90 fitting	–	0.8	13
New	Flat vent, 30° with ø 90 fitting	–	1.1	11
New	New upright vent, 30° with ø 90 fitting	–	1.1	10
New	New upright vent, 90° with ø 90 fitting	–	1.3	14

1

2

3

4

5

6

7

8





9

10

11

12

13

CONTROL ELEMENTS					
Model	EasyStart Select Control unit	EasyStart Timer Timer	EasyStart Remote Remote control	EasyStart Remote+ Remote control	EasyStart Call* Telephone Remote control
Order number	22 1000 34 13 00	22 1000 34 15 00	22 1000 34 23 00	22 1000 34 17 00	22 1000 34 01 00
Description	Basic version	Comfort version	Basic version	Comfort version	Operated by voice menu, text message, or smartphone app (available for iPhone and Android)
Functions	<ul style="list-style-type: none"> ▪ Heating/ventilation on/off ▪ Required temperature can be set using arrow keys (left/right) 	<ul style="list-style-type: none"> ▪ Heating/ventilation on/off ▪ Additional device on/off ▪ Program/delete pre-select mode ▪ Press and hold the function for immediate heating ▪ A second heater can be operated ▪ Required temperature can be set using arrow keys (left/right) 	<ul style="list-style-type: none"> ▪ Heating/ventilation on/off ▪ Operating time adjustable ▪ Air heaters also require a separate control element for inputting setpoints (EasyStart Timer) 	<ul style="list-style-type: none"> ▪ Heating/ventilation on/off ▪ Additional device on/off ▪ Program/delete pre-select mode ▪ Press and hold the function for immediate heating ▪ A second heater can be operated ▪ Required temperature can be set using arrow keys (left/right) 	<ul style="list-style-type: none"> ▪ Heating/ventilation on/off ▪ Program/delete pre-select mode ▪ Required temperature can be set
Timer programming	–	<ul style="list-style-type: none"> ▪ Three programming locations within seven days ▪ Selection of individual days of the week or one of three time periods (Mo.–Fr./Sa.+Su./Mo.–Su.) 	–	<ul style="list-style-type: none"> ▪ Three programming locations within seven days ▪ Selection of individual days of the week or one of three time periods (Mo.–Fr./Sa.+Su./Mo.–Su.) 	<ul style="list-style-type: none"> ▪ Three programming locations within seven days ▪ Selection of individual days of the week or one of three time periods (Mo.–Fr./Sa.+Su./Mo.–Su.)
Immediate start-up mode running time	Continuous heating mode preset	10–120 min. and continuous heating mode options	Adjustable 10, 20, 30, 40, 50 or 60 min.	10–120 min. and continuous heating mode options	10–120 min. and continuous heating mode options
Pre-ventilation**	Yes	Yes	Yes	Yes	Yes
Display interior temperature	Yes	Yes	–	Yes	Yes
Feedback	<ul style="list-style-type: none"> ▪ Status: Heater ▪ Status: Connection to the heater 	<ul style="list-style-type: none"> ▪ Status: Heater ▪ Status: Connection to the heater 	<ul style="list-style-type: none"> ▪ Data transfer successful ▪ Status: Heater ▪ Status: Connection to the heater 	<ul style="list-style-type: none"> ▪ Data transfer successful ▪ Status: Heater and Timer ▪ Status: Connection to the heater 	<ul style="list-style-type: none"> ▪ Status: Heater and timer ▪ Feedback by voice output or text message ▪ Status: Connection to the heater
Range	–	–	Up to 1 km under optimum conditions	Up to 1 km under optimum conditions	Unlimited (given network coverage)
Display	LED-illuminated ICON display. Lighting can be integrated with vehicle lighting circuit.	LED-illuminated matrix display. Lighting can be integrated with vehicle lighting circuit.	Two-tone LED	LED-illuminated matrix display	Display via smartphone app

* SIM card: 1.8-V or 3-V SIM card/pre-paid card from a network operator supporting the GSM 900/1800 (D-net, E-net) standard in Europe; use outside of country of purchase may incur roaming fees for EasyStart Call for outgoing or incoming text messages or incoming calls. Roaming fees may also be incurred near borders due to network overlap. When used with Airtronic, no separate control element is required for temperature setpoint input. EasyStart Call is not designed for use in conjunction with other control elements.

** Depending on heater type

1

2

3

4

5

6

7

8

9

10

11

12

13



3 | AIRTRONIC: TECHNOLOGY

ACCESSORIES

	EasyStart Select	EasyStart Timer	EasyStart Remote	EasyStart Remote+	EasyStart Call
Temperature sensor for displaying interior temperature	–	22 1000 34 22 00	–	Included in the product package	Included in the product package
Timer trim	–	22 1000 51 41 00	–	–	–

APPROVED COMBINATIONS OF CONTROL ELEMENTS

		SLAVE CONTROL ELEMENTS			
		EasyStart Select	EasyStart Timer	EasyStart Remote	Button
MASTER CONTROL ELEMENTS	EasyStart Timer	X	X	X	X
	EasyStart Remote+	X	X	–	Included in the product package

EasyStart Call

EasyStart Call is not currently designed for use in conjunction with other EasyStart control elements.

EasyStart Timer and EasyStart Remote+

APPROVED COMBINATIONS OF HEATER AND CONTROL ELEMENT:

OPTION 1

You can control a second heater by using the DAT line (purple) and the diagnostic line (blue and white). However, it is not possible to connect an additional control element. Diagnostics can be run for both heaters.

OPTION 2

You can switch on any device by activating the switch output (switch on/vehicle blower output). A second control element can be connected via the DAT line (purple). Diagnostics is available for the first heater but not for the second.

COMPATIBILITY MODE FOR HEATERS WITHOUT EBERSPÄCHER DIAGNOSTICS, E.G. D8 LC AIR HEATER

Heater diagnostics cannot be run via the control element. Air heaters also require a separate control element for inputting setpoints.

- 1
- 2
- 3
- 4
- 5
- 6
- 7
- 8
- 9
- 10
- 11
- 12
- 13

3 | AIRTRONIC: OPTIONAL ADD-ONS

AIR-RECIRCULATION MODE WITH INTERIOR TEMPERATURE SENSOR:



1

2

3

4

5

6

7

8

9

10

11

12

13

STANDARD SETUP:

Air-recirculation mode with measurement of actual temperature by temperature sensor in heater.

OPTIONAL ADD-ON 1:

Fresh-air mode with measurements of actual temperature using exterior temperature sensor installed separately in a suitable area for measuring the required temperature.

OPTIONAL ADD-ON 2 – PRE-VENTILATION:

Airtronic heaters come with the pre-ventilation function. Both this and the EasyStart control elements are automatically detected (see Commissioning EasyStart control elements). For other heaters or control elements, see the technical information.

FRESH-AIR MODE WITH EXTERIOR SENSOR:



OVERVIEW: FRESH-AIR MODE AND TEMPERATURE DISPLAY OPTIONS ON THE EASYSTART CONTROL ELEMENTS, EasyStart Timer EXAMPLE:

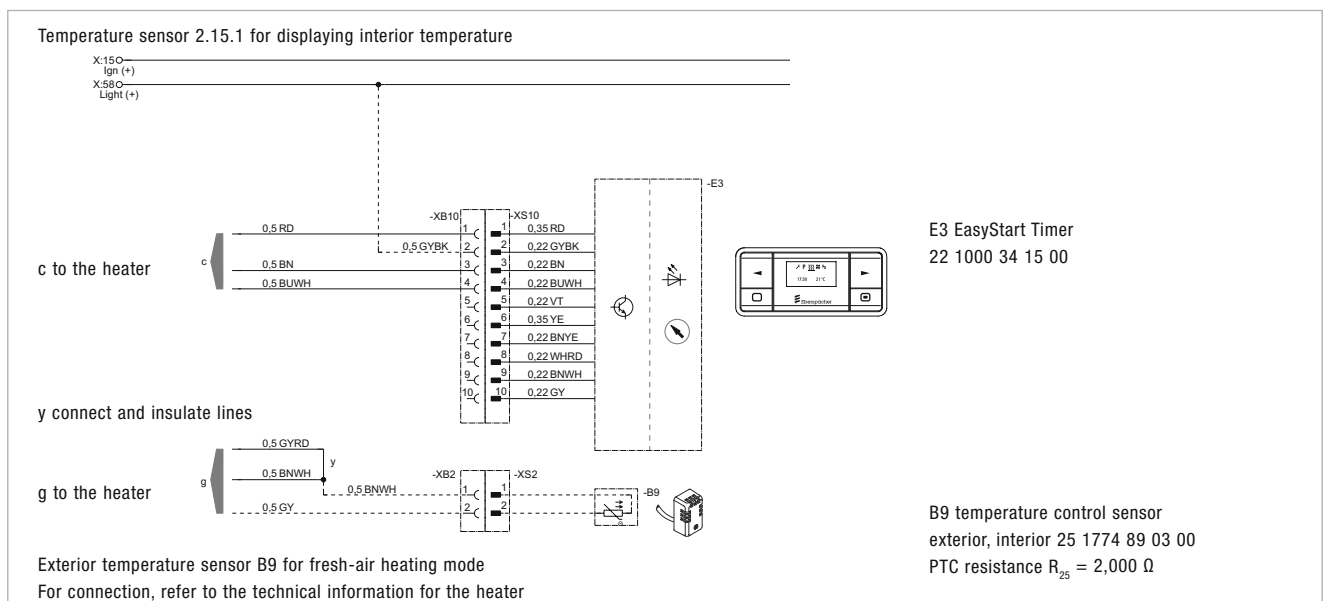

- 1
- 2
- 3
- 4
- 5
- 6
- 7
- 8
- 9
- 10
- 11
- 12
- 13

4 | SERVICE: DIAGNOSTIC TOOLS

EBERSPÄCHER DIAGNOSTICS OPTIONS:

- **With EasyStart control elements:**
See heater and control element fault finding on the Service Portal
- **With existing diagnostic devices 22 1512 89 0000 and 22 1529 89 0000 and with the new diagnostic device 22 1545 89 00 00**
See heater fault finding and introduction to diagnostic device on the Service Portal **NEW**
- **EDiTH Basic, requires PC, ISO adapter and software:**
See heater fault finding and introduction to EDiTH on the Service Portal
- **EDiTH Expert, requires PC, EDiTH expert hardware and software:**
See heater fault finding and introduction to EDiTH on the Service Portal

Testing heaters using	Control element/ diagnostic device	EDiTH Basic	EDiTH Expert	EDiTH Expert expansions
Full test without PC	X			
Full test with PC		X		
Control unit test with PC			X	X

USE THE NEW DIAGNOSTIC DEVICE 22 1545 89 00 00:

- If EasyStart Timer or Remote+ control element are not installed
- If EasyStart Select, Timer, Remote, Remote+ or Call is not installed
- If EDiTH Basic and PC are available
- As a replacement for defective diagnostic devices 22 1512 89 00 00 and 22 1529 89 00 00
- For diagnosing the Hydronic 2 Economy heater

DIAGNOSTIC DEVICES:

- For correct commissioning or rapid diagnostics in vehicles, without a diagnostics-enabled control element
- If there is no PC
- Minimal installation

EDITH BASIC:

- Reads out general heater data, e.g. running times for function tests in the vehicle and on the test bench, parameter displays
- Individual component activation for components testing or line filling
- Recommended basic installation

EDITH EXPERT:

- Function testing of dismantled control units
- Diagnostics of control units without Eberspächer diagnostics or if special hardware activation is needed
- For advanced service partners who can repair all types of heaters

1

2

3

4

5

6

7

8

9

10

11

12

13

4 | SERVICE: TESTING EQUIPMENT

TESTING EQUIPMENT FOR HEATERS:



Designation	Item no.
EDiTH Basic + USB adapter + CD-ROM	22 1541 89 00 00
Diagnostic device (new timer)	22 1545 89 00 00
Adapter cable	–
Hydronic I 3/4/5 kW	22 1000 31 63 00
Airtronic	22 1000 31 86 00
Hydronic 16/24/30/35	22 1000 31 66 00
Compact air heater	22 1000 30 69 00
Air heater C (D1L C DAF)	22 1000 30 20 00
D9W, Hydronic 10 (old diagnostic timer)	22 1000 30 05 00
D9W, Hydronic 10	22 1000 31 83 00
Hydronic 10 (25 2161/25 2162)	22 1000 32 52 00
Hydronic M 2	22 1000 33 78 00*
D1/3LC MAN	22 1000 30 32 00
Hydronic 30 Neoplan	22 1000 31 16 00
D1LC/D1LC compact RVI	22 1000 31 23 00
D1/3LC compact DAF	22 1000 31 21 00
Hydronic 2 adapter (OEM heater)	22 1000 32 64 00
Hydronic 2 Economy/Comfort adapter cable	22 1000 33 78 00
IPCU ISO adapter	22 1000 32 74 00
USB adapter + CD-ROM**	22 1543 89 00 00

* From June 2012, the cable harness is supplied with the interface to the adapter above.

** Required for existing diagnostics if you change to a PC with no serial interface.

TESTING EQUIPMENT FOR CONTROL UNITS AND HEATERS:

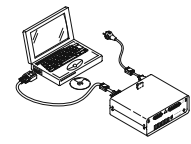

Designation	Item no.
EDiTH Expert incl. USB adapter + CD-ROM	22 1542 89 00 00
Hydronic I adapter	22 1533 89 00 00
Hydronic 2 adapter	22 1534 89 00 00
Compact air heater D2I, adapter	22 1535 89 00 00
LC air heater D2H, adapter	22 1536 89 00 00
Airtronic adapter	22 1537 89 00 00
Hydronic 10 adapter	22 1538 89 00 00
Hydronic 16/24/30/35, adapter	22 1539 89 00 00
Adapter for full testing cable	22 1540 89 00 00
IPCU adapter	22 1000 32 76 00
USB adapter + CD-ROM*	22 1543 89 00 00

1

2

3

4

5

6

7

8

9

10

11

12

13

4 | SERVICE: A/C KIT WITH IPCU FOR CONTROLLING THE VEHICLE'S FAN

THE IPCU IS PART OF THE A/C KIT:

A/C kit should be installed first!

OPTIONS:

- See installation recommendations/Service Portal as to whether A/C kit is available
- If there is no A/C kit, see Service Portal:
- IPCU programming list (Download area)
- Call the Technical Hotline

WARNING:

- Taking measurements requires specialist knowledge in automotive electronics
- Taking measurements requires the vehicle manufacturer's circuit diagrams
- We can accept no liability for measuring errors which result in permanent damage to the vehicle's air-conditioning system and/or measuring devices and diagnostics equipment

PROGRAMMING OPTIONS 1:

Adapter cable for IPCU configuration

Order no.: 22 1000 32 74 00

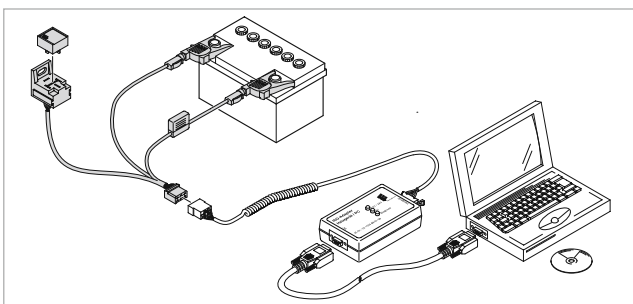

INTRODUCTION TO TAKING MEASUREMENTS WITH THE RELEVANT INSTRUMENTS:

Universal multimeter with frequency meter and duty cycle or an oscilloscope (workshop equipment).

TAKING MEASUREMENTS:

- Preselect voltage meter measuring range minimum U3; measure according to circuit diagram
- Switch on ignition
- Change fan speed using A/C control element
- If the voltage is changeable between 0–5 V or 0–10 V: voltage divider, choose a low fan speed, note voltage values

No clear change:

- Switch fan to 0, measure direct current in voltage range
- Voltage to battery: **Low activity** or
- 0 V: **High activity**, note
Important: do not exceed maximum voltage!
- Switch to frequency measurement, **read and note** frequency
- Select low fan speed, switch to duty cycle and note **duty cycle in %**
- Choose a fan speed that puts the duty cycle at ~50 %, Switch the measuring device to minimum U13, **read voltage, multiply by 2** and note

PROGRAMMING OPTIONS 2:

IPCU configuration expansion

Order no.: 22 1000 32 76 00

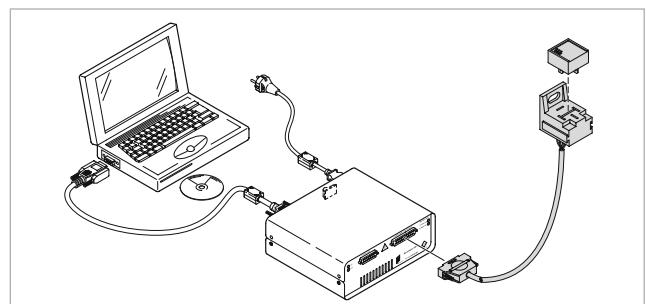

1

2

3

4

5

6

7

8

9

10

11

12

13

4 | SERVICE: SERVICE/REPLACEMENT DEVICE PROGRAM

OVERVIEW OF REPLACEMENT HEATERS (RECONDITIONED DEVICES, FOR DEFECTS OCCURRING BETWEEN 1 AND 48 MONTHS):

HEATER	Designation	Order number
Hydronic B4W S	Facelift version replacement device	20 1852 97 01 00
Hydronic B4W SC	Facelift version replacement device	20 1821 97 01 00
Hydronic B5W S	Facelift version replacement device	20 1819 97 01 00
Hydronic B5W SC	Facelift version replacement device	20 1820 97 01 00
Hydronic D4W S	Facelift version replacement device	25 2355 97 01 00
Hydronic D4W SC	Facelift version replacement device	25 2221 97 01 00
Hydronic D5W S 12 V	Facelift version replacement device	25 2217 97 01 00
Hydronic D5W SC	Facelift version replacement device	25 2219 97 01 00
Hydronic D5W S 24 V	Facelift version replacement device	25 2218 97 01 00
Hydronic 2 Economy D4S	Replacement device	25 2554 97 01 00
Hydronic 2 Economy D5S	Replacement device	25 2526 97 01 00
Hydronic 2 Economy B4S	Replacement device	20 1909 97 01 00
Hydronic 2 Economy B4S	Replacement device	20 1904 97 01 00
Airtronic D2 12 V	Replacement device	25 2069 97 01 00
Airtronic D2 24 V	Replacement device	25 2070 97 01 00
Airtronic D4 12 V	Replacement device	25 2113 97 01 00
Airtronic D4 24 V	Replacement device	25 2114 97 01 00
Airtronic D4 Plus 12V	Replacement device	25 2484 97 01 00
Airtronic D4 Plus 12V	Replacement device	25 2498 97 01 00

1

2

3

4

5

6

7

8

9

10

11

12

13

4 | SERVICE: REPLACEMENT DEVICE PROGRAM

OVERVIEW OF NEW DEVICES (REQUIRED FOR DEFECTS OCCURRING FROM 48 MONTHS):

HEATER	Designation	Order number
Hydronic B4W S 12 V	Facelift version replacement device	20 1852 97 02 00
Hydronic B4W SC 12 V	Facelift version replacement device	20 1821 97 02 00
Hydronic D4W S 12 V	Facelift version replacement device	25 2355 97 02 00
Hydronic D4W SC 12 V	Facelift version replacement device	25 2221 97 02 00
Hydronic B5W S 12 V	Facelift version replacement device	20 1819 97 02 00
Hydronic B5W SC 12 V	Facelift version replacement device	20 1820 97 02 00
Hydronic D5W S 12 V	Facelift version replacement device	25 2217 97 02 00
Hydronic D5W SC 12 V	Facelift version replacement device	25 2219 97 02 00
Hydronic D5W S 24 V	Facelift version replacement device	25 2218 97 02 00
Airtronic D2 12 V	Replacement device	25 2069 97 02 00
Airtronic D2 24 V	Replacement device	25 2070 97 02 00
Airtronic D4 12 V	Replacement device	25 2113 97 02 00
Airtronic D4 24 V	Replacement device	25 2114 97 02 00

PLEASE NOTE THE FOLLOWING AS REGARDS HYDRONIC HEATERS:

When replacing older generation heaters with facelift devices, you will also need the following parts:

- 1x facelift unit mounting bracket 25 2220 80 00 01
- 1x fastening screw 100 10 101
- 2x 20/18 water hose reducers 20 1645 89 00 06

Old generation Hydronic 4 kW heaters are 20 mm shorter than the facelifted 4 kW heater.

4 | SERVICE: ADDITIONAL HEATERS

ADDITIONAL HEATERS	Designation	Order number
D3W Z 12 V	VW T4, PME	25 2121 05 00 00
D5W Z 12 V	VW Sharan MPV from 2000 onwards	25 2163 05 00 00
D5Z-F 12 V	VW Sharan MPV from 2004 onwards	25 2278 05 00 00
D5W Z 12 V	DC Sprinter T1N	25 2162 05 00 00
D5W Z 12 V	DC TO (Vito + V-Class)	25 2124 05 00 00
D3W Z 12 V	Opel Corsa Monocub	25 2253 05 00 00
D3W Z 12 V	Opel Omega 2.5 l	25 2249 99 02 00

1

2

3

4

5

6

7

8

9

10

11

12

13

5 | THE BENEFITS FOR WORKSHOPS

Robust design, high-performance, sophisticated technology: Eberspächer fuel heaters “made in Germany” have made a name for themselves around the world. For every application, our innovative heating technology ensures an extremely comfortable degree of warmth as soon as the driver or passengers enter a vehicle. Use our products for the benefit of your customers – and therefore to your advantage. The following pages present a summary of the most important reasons why both you and your customers should choose Eberspächer.

1

HIGHER PROFITS:

Because you can buy heaters at a great price, and so each one that you sell makes a visible difference to the bottom line.

2

PRE-HEATER INSTEAD OF DISCOUNT:

These days, it's all about “trade”. Your customers ask for perks, and it impacts on your sales. There is another way! Rather than offering your customers a percentage discount, present them with a lucrative offer package: an Eberspächer heater at an especially attractive special price.

4

5

POTENTIAL:

A large percentage of customers who have bought a pre-heater would opt for this extra again with their next vehicle.

7

PARTNERSHIP:

As an Eberspächer Partner you are comprehensively trained so that you have all the necessary know-how on Eberspächer pre-heaters. You also have access to our Web portal where you can obtain important information such as installation recommendations, prices and catalogs. At the start of the season you receive our comprehensive advertising package.

8

9

10

11

12

13

HERE'S HOW YOU CAN SUPPORT SALES INTERNALLY:

- Your customer will only buy something he knows and loves. That means your demonstration vehicles should have a pre-heater too!
- Motivation is everything: in the run-up, make sure that your salespeople are fired up and fully-versed on the subject of pre-heaters.
- To make sure they close the deal: provide your employees with impressive sample calculations for available leasing and finance offers.
- Go for maximum impact: drive the advertising message on your homepage, in your newsletter or with direct mail too.

SO WHEN YOU'RE PLANNING, HERE ARE THE KEY AREAS TO CONSIDER:

- Provide your sales team and your parts and service managers with campaign information in good time.
- Set out which vehicle models the promotional package can be offered for.
- Make sure you provide a careful calculation of the package price.
- Order our advertising materials and use them for optimum effect at your premises.
- Make sure you have the necessary parts in stock!
- Check that your pre-heater workshop knowledge is up-to-date and if you need a refresher, use the training provided by your distributor and Eberspächer.
- Together with your team, work through a guideline for your sales discussions. Next – some compelling arguments!

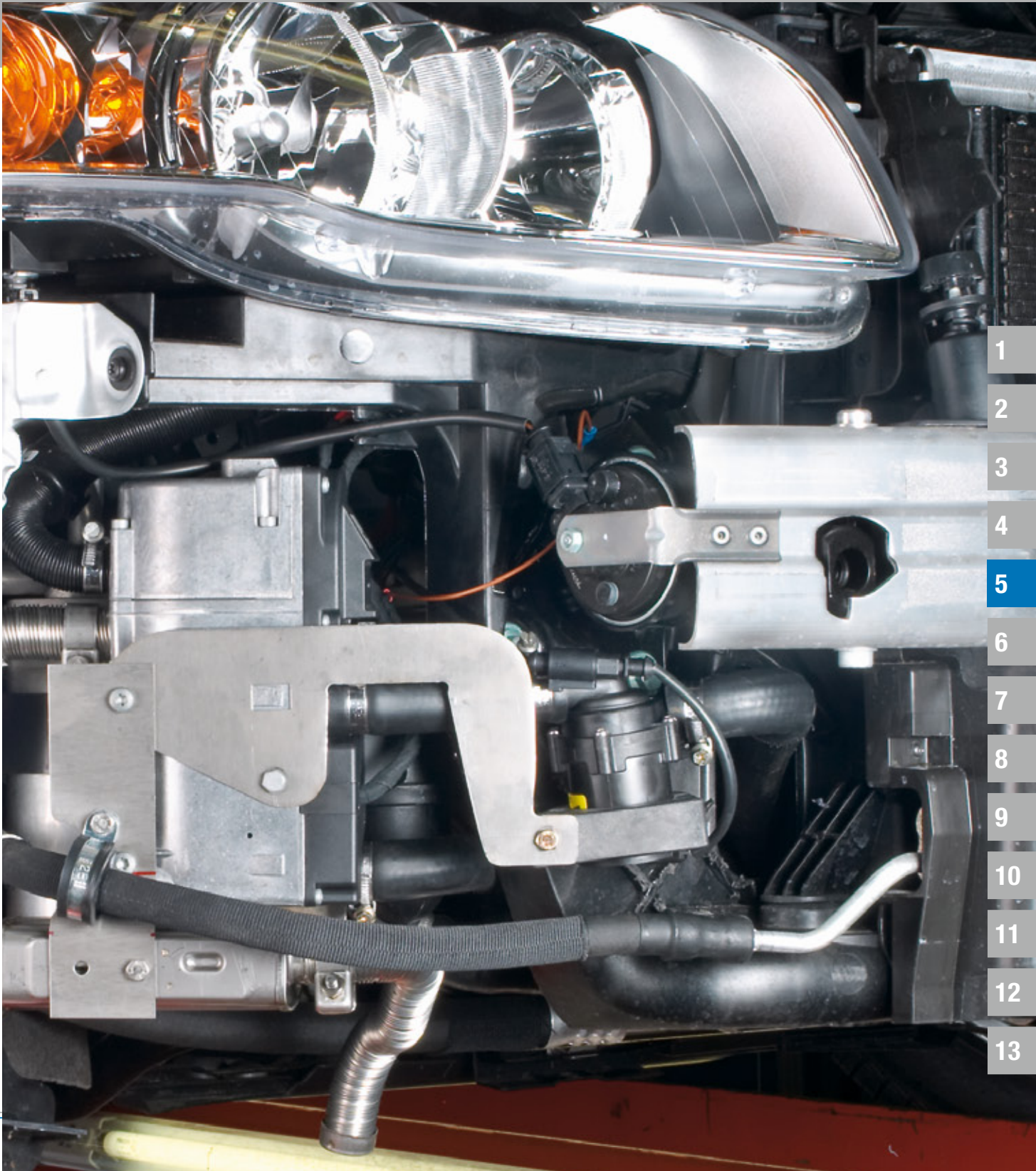

- 1
- 2
- 3
- 4
- 5
- 6
- 7
- 8
- 9
- 10
- 11
- 12
- 13

5 | THE BENEFITS FOR END CUSTOMERS



CUSTOMER BENEFITS FOR CAR OWNERS:

- 1
- 2
- 3
- 4
- 5
 - Not only do you no longer have to waste time scraping the ice off the windows in the morning – a pre-heater also ensures you have a pleasantly warm car to get into after playing sports, having a wellness treatment, or spending an evening at the movies or theater. A pre-heater is also a real status symbol which every high-end car should have.
 - The Eberspächer pre-heater ensures that your windows are thawed in time for you to leave, and do not fog up. A clear view of the road and no need to wear a thick winter jacket at the steering wheel – for real safety!
 - A cold start puts as much of a burden on the engine as 70 kilometers of highway driving. A modern pre-heater prevents this, because it heats not only the interior but also your engine's cooling circuit. The wear-intensive cold-start phase is avoided, which helps to maintain your vehicle's value.
 - An engine warmed by a pre-heater consumes considerably less fuel when starting, because the cold-starting or warm-up phase described earlier does not occur. As a rule, this easily offsets the extra fuel required to operate the pre-heater.
 - A warm start reduces pollution emissions by around 60 percent compared with a cold start. This not only eases your conscience but also actively protects the environment. The pollutant reduction is therefore one of the strongest arguments in favor of using a pre-heater.
- 6
- 7
- 8
- 9
- 10
- 11
- 12
- 13



CUSTOMER BENEFITS FOR MOTOR HOME OWNERS:

- Winters at our latitudes last much longer than we realize. Ice in April is not unusual! And the thermometer often drops below zero as early as October. On hot summer days, just select pre-ventilation and you can keep your car supplied with fresh outside air while it is parked as well.
- The heater is supplied with fuel from the vehicle's fuel tank so you needn't worry about gas bottles and connections when traveling abroad.
- Eberspächer heaters feature low fuel and electricity consumption.
- The heater can be conveniently operated using presets, remote control or phone.
- Eberspächer fuel heaters are now even quieter.
- The heater is installed in the interior – space-saving underfloor installation or in the engine compartment is also possible.
- Heating is permitted worldwide even while driving – without additional components.
- The heater's design is particularly easy to service and maintain.



CUSTOMER BENEFITS FOR SPECIAL-PURPOSE VEHICLE OWNERS:

- Lower operating costs due to high efficiency.
- Reliable starting even in low temperatures.
- Comfortable temperatures in mobile workplaces and optimal temperature controls for storage compartments.
- Eberspächer diesel-fueled heaters are now even quieter.
- The heater is installed in the interior – space-saving underfloor installation or in the engine compartment is also possible.
- The heater's design is particularly easy to service and maintain.



CUSTOMER BENEFITS FOR BOAT OWNERS:

- Eberspächer heaters feature low fuel and electricity consumption.
- The heater provides exactly the climate you want in the cabin.
- You can operate your heater conveniently using the controller, presets or phone.
- Eberspächer diesel-fueled heaters are now even quieter.
- You need not sacrifice any room in the cabin in order to install the heater as they can be housed in any space with good external ventilation, e.g. in the storage locker, the cockpit or other storage areas.
- The heater's design is particularly easy to service and maintain.
- The heater also provides hot water for your shower or general use.



- 1
- 2
- 3
- 4
- 5
- 6
- 7
- 8
- 9
- 10
- 11
- 12
- 13

6 | WATER LINES

GENERAL INFORMATION:

- Install water pumps no higher than the heater and preferably lower.
 - All water lines for heaters must always be below the engine's coolant level.
 - When installing a water heater, always use water hoses approved for use with vehicles, otherwise there is a danger of parts of the hose becoming flattened or layers of the hose perishing, blocking the water circuit.
 - Always secure water hoses with hose clips at connections.
 - Always route water hoses so that they are not affected by moving parts and cannot be chafed. Pay particular attention to the heavy vibration caused by switching the engine on and off.
 - Always use a large radius when routing water hoses to prevent kinking, and do not leave hoses hanging loose.
 - Protect water hoses from intense heat or even contact with hot engine parts, e.g. the exhaust pipe.
 - Always vent the whole water circuit of a vehicle after any assembly operation.
- 1
- 2
- 3
- 4
- 5
- 6**
- 7
- 8
- 9
- 10
- 11
- 12
- 13
- Please also refer to the safety information on this section in the heater documentation.

6 | WATER LINES

Flowtronic 6000 SC water pump
 With magnetic coupling and mounting bracket
 Water flow rate 6,000 l/h at 0.4 bar

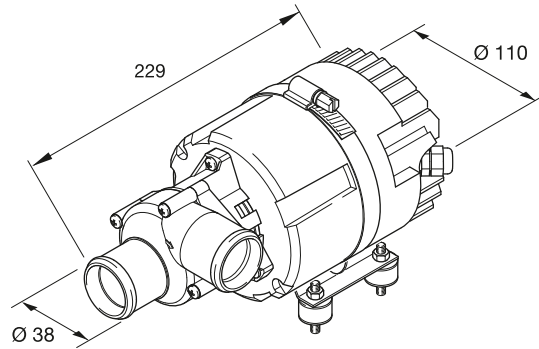

Airtronic	Airtronic M	Airtronic L	Air heater 8 L / V 7 S	Hydronic 4 / 5 KW	Hydronic M / M2	Hydronic L / L2	Order no.
-----------	-------------	-------------	------------------------	-------------------	-----------------	-----------------	-----------

24 V

25 2488 25 00 00

Flowtronic 6000 SC spares kit

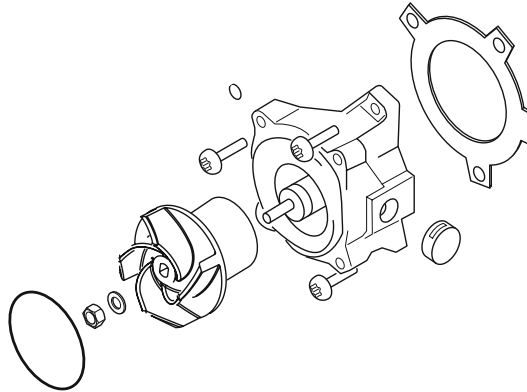

25 2488 99 25 10

Flowtronic 5000 water pump
 With mounting bracket, water flow rate 5,200 l/h at 0.2 bar

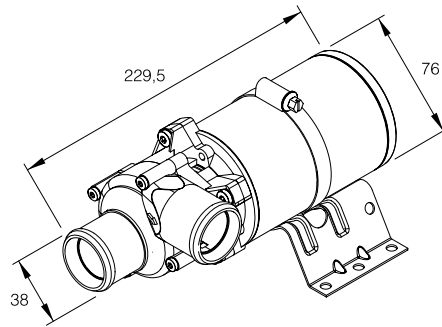

24 V

25 2488 26 00 00

Flowtronic 5000 spares kit
 For water pump 25 1818 29 00 00

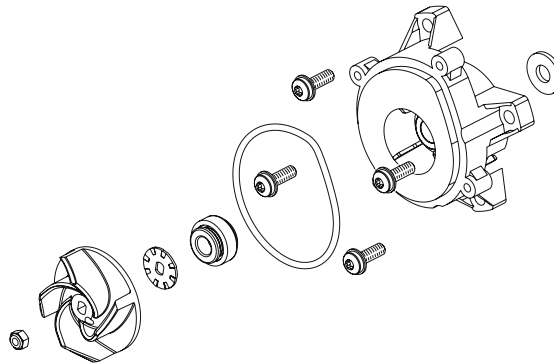

25 2488 99 26 10

- 1
- 2
- 3
- 4
- 5
- 6
- 7
- 8
- 9
- 10
- 11
- 12
- 13

6 | WATER LINES

Flowtronic 5000 S water pump
 With magnetic coupling and mounting bracket
 Water flow rate 5,200 l/h at 0.2 bar

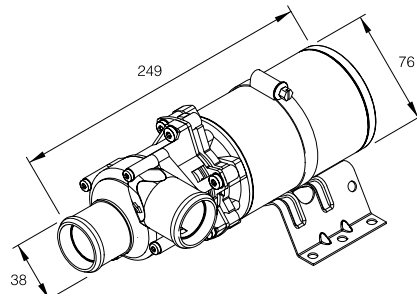

24 V

Airtronic	Airtronic M	Airtronic L	Air heater 8 L / V / 7 S	Hydronic 4 / 5 KW	Hydronic M / M2	Hydronic L / L2	Order no.
-----------	-------------	-------------	--------------------------	-------------------	-----------------	-----------------	-----------

25 1818 30 00 00

Flowtronic 1200 S water pump
 With magnetic coupling, 200 mm long cable harness
 12 V without mounting bracket, 24 V with mounting bracket
 Water flow rate 700 l/h at 0.3 bar

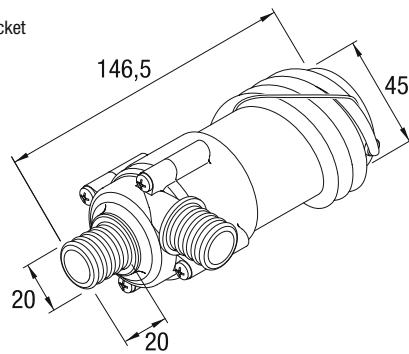

12 V

24 V with mounting bracket installed

Airtronic	Airtronic M	Airtronic L	Air heater 8 L / V / 7 S	Hydronic 4 / 5 KW	Hydronic M / M2	Hydronic L / L2	Order no.
-----------	-------------	-------------	--------------------------	-------------------	-----------------	-----------------	-----------

25 1815 25 01 00

25 1928 80 02 00

Flowtronic 800 S water pump
 Water flow rate 820 l/h at 0.1 bar

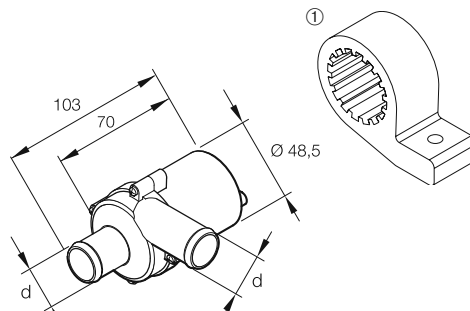

12 V, d = 20 mm

24 V, d = 18 mm

① See page 121 for mounting bracket

Airtronic	Airtronic M	Airtronic L	Air heater 8 L / V / 7 S	Hydronic 4 / 5 KW	Hydronic M / M2	Hydronic L / L2	Order no.
-----------	-------------	-------------	--------------------------	-------------------	-----------------	-----------------	-----------

25 2275 25 00 00

25 2218 25 00 00

Water pump
 With mounting bracket installed, adapter cable, M6x12 hexagon screws
 Water flow rate 850 l/h at 0.1 bar

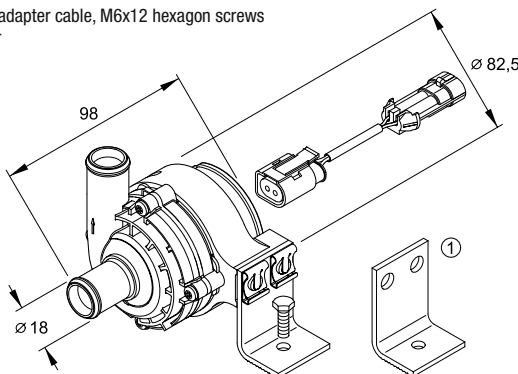

12 V

24 V

① See page 121 for mounting bracket

Airtronic	Airtronic M	Airtronic L	Air heater 8 L / V / 7 S	Hydronic 4 / 5 KW	Hydronic M / M2	Hydronic L / L2	Order no.
-----------	-------------	-------------	--------------------------	-------------------	-----------------	-----------------	-----------

25 2217 27 00 00

25 2009 25 00 00

6 | WATER LINES

Water hose

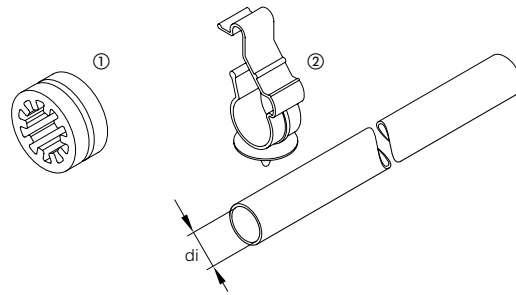

①
See page 121 for spacer ring

②
See page 120 for water hose fastening parts

~ = Check connection diameter

di = 15 mm, L = linear m
 di = 18 mm, L = 1 m
 di = 20 mm, L = 1 m
 di = 38 mm, L = 1 m

Airtronic	Airtronic M	Airtronic L	Air heater 8 L / V 7 S	Hydronic 4 / 5 KW	Hydronic M / M2	Hydronic L / L2	Order no.
				~			360 75 020
				■	~		360 75 407
				~	■	~	360 75 408
						■	360 75 413
<hr/>							
Reducer hose							
<p>Di = 20 mm, di = 15 mm Di = 20 mm, di = 18 mm Di = 22 mm, di = 18 mm</p>							
~ = Check connection diameter							
<hr/>							
Water hose							
<p>di = 15 mm/180°, L1 = 50 mm, L2 = 50 mm, L3 = 75 mm di = 20 mm/180°, L1 = 50 mm, L2 = 50 mm, L3 = 83 mm di = 18 mm/180°, L1 = 45 mm, L2 = 55.5 mm, L3 = 60.5 mm</p>							
~ = Check connection diameter							
<hr/>							
Water hose							
<p>di = 18 mm, L = 500 mm di = 18 mm, L = 2,000 mm di = 20 mm, L = 2,000 mm</p>							
~ = Check connection diameter							

- 1
- 2
- 3
- 4
- 5
- 6
- 7
- 8
- 9
- 10
- 11
- 12
- 13

6 | WATER LINES

Water hose for shortening

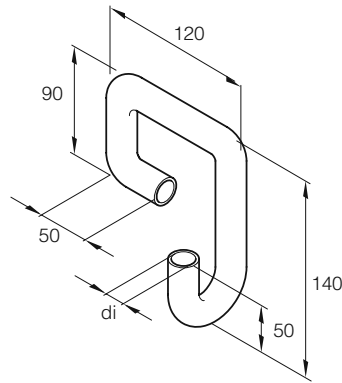

~ = Always used for connecting the Hydronic 2/Hydronic 2 C to the water pump

di = 20 mm

Water hose

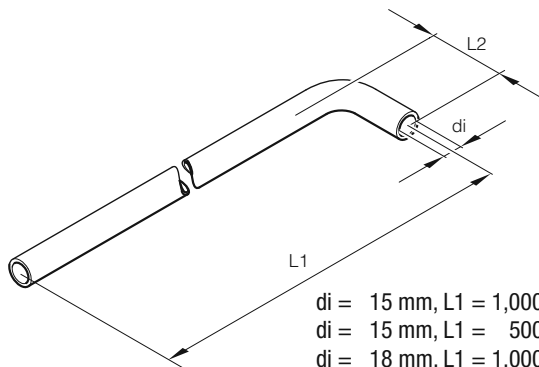

- di = 15 mm, L1 = 1,000 mm, L2 = 50 mm
- di = 15 mm, L1 = 500 mm, L2 = 50 mm
- di = 18 mm, L1 = 1,000 mm, L2 = 50 mm
- di = 18 mm, L1 = 840 mm, L2 = 240 mm
- di = 20 mm, L1 = 120 mm, L2 = 60 mm

~ = Check connection diameter

Connection pipe

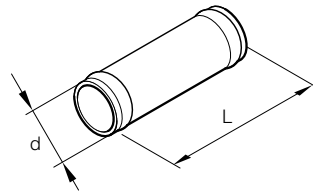

- Brass, d = 15 mm, L = 55 mm
- Brass, d = 18 mm, L = 55 mm
- Plastic, d = 20 mm, L = 60 mm
- Brass, d = 22 mm, L = 55 mm
- Brass, d = 38 mm, L = 60 mm

~ = Check connection diameter

Ventilation pipe
Brass

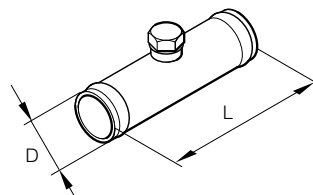

~ = Check connection diameter

D = 18 mm, L = 65 mm

Airtronic	Airtronic M	Airtronic L	Air heater 8 L / V 7 S	Hydronic 4 / 5 KW	Hydronic M / M2	Hydronic L / L2	Order no.
				~			25 2526 80 01 02
			~	~			20 1528 88 00 01
			~	~			20 1533 88 00 05
				~			20 1645 80 00 01
				~			20 1645 89 00 01
				~			24 0310 80 00 02
				~			20 1533 88 00 03
				~			20 1528 88 00 03
				~			22 1000 10 01 03
				~			20 1645 89 00 07
							25 1214 89 00 21
				~			20 1645 89 01 00

6 | WATER LINES

Reducer

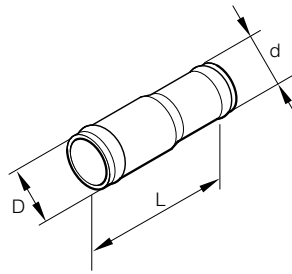

- Brass, D = 18 mm, d = 15 mm, L = 60 mm
- Plastic, D = 20 mm, d = 15 mm, L = 60 mm
- Plastic, D = 20 mm, d = 18 mm, L = 60 mm
- Brass, D = 20 mm, d = 16 mm, L = 60 mm
- Brass, D = 22 mm, d = 15 mm, L = 60 mm
- Brass, D = 22 mm, d = 18 mm, L = 60 mm
- Brass, D = 22 mm, d = 20 mm, L = 60 mm

~ = Check connection diameter

T-piece Brass

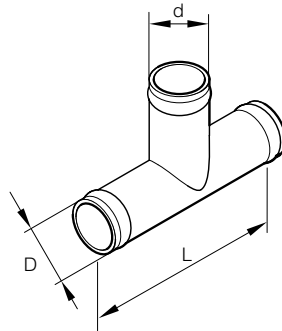

- D = 18 mm, d = 15 mm, L = 60 mm
- D = 18 mm, d = 18 mm, L = 75 mm
- D = 20 mm, d = 18 mm, L = 75 mm
- D = 20 mm, d = 20 mm, L = 75 mm
- D = 38 mm, d = 38 mm, L = 120 mm

~ = Check connection diameter

Combi valve with thermostat function With five connections

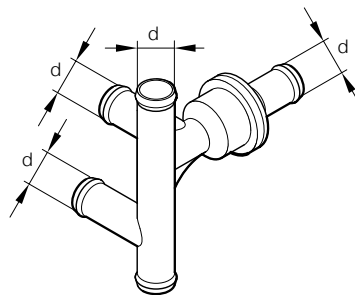

* not suitable for Hydronic 2 Comfort

Also required: T-piece, page 71

* d = 20 mm

Combi valve with thermostat function With six connections

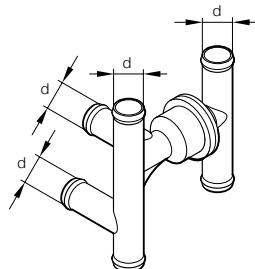

* not suitable for Hydronic 2 Comfort

* d = 20 mm

Airtronic	Airtronic M	Airtronic L	Air heater 8 L / V 7 S	Hydronic 4 / 5 KW	Hydronic M / M2	Hydronic L / L2	Order no.
				■	~		20 1645 80 02 01
				~	■		22 1000 10 01 05
				~	■		22 1000 10 01 04
				~	■		24 0176 89 00 01
				~	~		25 1214 89 00 11
				~	~		20 1645 89 00 05
				~	■		25 1214 89 00 04
				■	~		25 1214 89 16 00
				■	~		20 1645 89 10 00
				~	■		20 1645 89 11 00
				~	■		20 1673 80 11 00
					■		25 1371 89 04 00
				~	■		25 2014 80 72 00
				~	■		25 2014 80 62 00

- 1
- 2
- 3
- 4
- 5
- 6
- 7
- 8
- 9
- 10
- 11
- 12
- 13

6 | WATER LINES

Water check valve

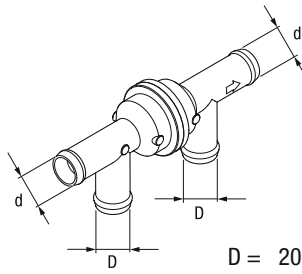

D = 20 mm, d = 18 mm
D = 20 mm, d = 20 mm

Airtronic	Airtronic M	Airtronic L	Air heater 8 L / V 7 S	Hydronic 4 / 5 KW	Hydronic M / M2	Hydronic L / L2	Order no.
				■			22 1000 10 11 00
				■			22 1000 10 10 00

Water check valve

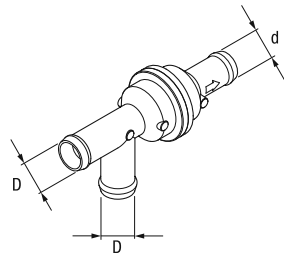

D = 20 mm, d = 18 mm
D = 20 mm, d = 20 mm

				■			22 1000 10 12 00
				■			22 1000 10 09 00

Water check valve

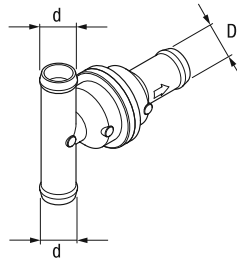

D = 20 mm, d = 18 mm
D = 20 mm, d = 20 mm

				■			22 1000 10 13 00
				■			22 1000 10 07 00

Water check valve

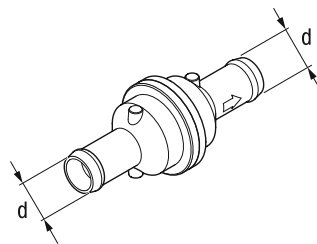

d = 18 mm
d = 20 mm

				~	~		22 1000 10 14 00
				■	■		22 1000 10 08 00

Thermostat

Brass, switch temperature 70–75 °C

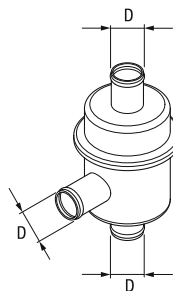

D = 18 mm, d = 18 mm, D1 = 48 mm, L = 109 mm
D = 20 mm, d = 20 mm, D1 = 48 mm, L = 112 mm

				■	~		330 00 123
				~	■		330 00 124

6 | WATER LINES

Heat-shrink fit hose
Anti-chafing protector for water hose

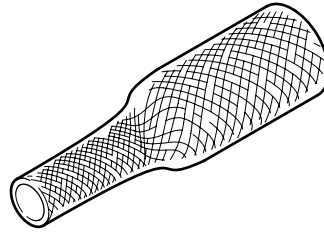

ø 40 mm/ø 20 mm

Safety hose
Aluminum/paper/plastic temperature/anti-chafing protector
for water hoses with ø 18 mm and ø 20 mm

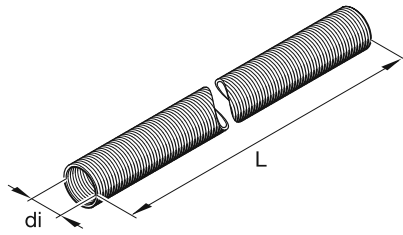

di = 30 mm, L = 2 m

Airtronic	Airtronic M	Airtronic L	Air heater 8 L / V 7 S	Hydronic 4 / 5 KW	Hydronic M / M2	Hydronic L / L2	Order no.
							360 00 333
							10 2114 25 02 00

1

2

3

4

5

6

7

8

9

10

11

12

13



- 1
- 2
- 3
- 4
- 5
- 6
- 7
- 8
- 9
- 10
- 11
- 12
- 13

7 | AIR LINES

GENERAL INFORMATION:

- Heating-air throughput is at its highest in a heater if the airflow is unimpeded. Heating-air lines reduce heating-air throughput.
- In order to give you the opportunity to check that the installation you have planned does not reduce the heating air throughput to an inadmissible level, we have calculated a heater guide number for each heater and a line guide number for each air line.
- The total of the line guide numbers of the heating-air lines connected to the heater must not be greater than the heater guide number, as otherwise the air flow temperature would be inadmissibly high and the overheating sensor would respond.
- If the total of the line guide numbers is greater than the heater guide number, the total can be reduced by selecting a larger diameter for the air lines.

RULE OF THUMB:

Double cross-section or two lines the same, routed in parallel = 1/4 of the guide number.

Example:

Hose \varnothing 60 mm

Cross-section A = 19.6 cm², guide number 1.0

Hose \varnothing 75,

Cross-section A = 44.2 cm², guide number 0.25

With smooth welded pipes, the line guide number is only half that of the flexible hose with the same diameter (i.e. double pipe length).

1

2

3

4

5

6

7

8

9

10

11

12

13

7 | AIR LINES

1
Flexible hose (linear m)
Aluminum/paper/plastic, for heating-air line in interior

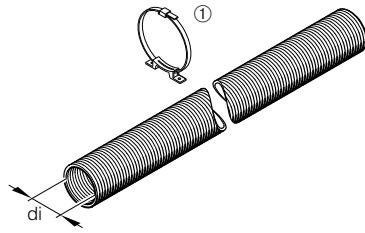

①
See page 120 for air hose clips

~ = Check connection diameter

di = 50 mm
di = 60 mm
di = 75 mm
di = 90 mm
di = 100 mm

2
Flexible hose (linear m)
Plastic hose with metal spiral, suitable for outside installation

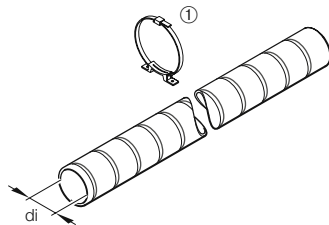

①
See page 120 for air hose clips

~ = Check connection diameter

di = 60 mm, (max. 4 m long)
di = 75 mm, (max. 4 m long)
di = 90 mm, (max. 4 m long)
di = 100 mm, (max. 4 m long)

3
Muffler
Hot air, aluminum

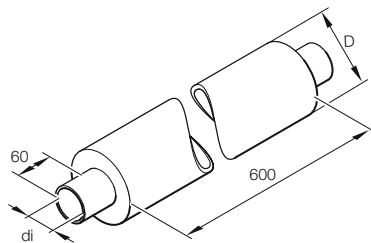

~ = Check connection diameter

di = 75 mm, D = 120 mm
di = 90 mm, D = 140 mm
di = 100 mm, D = 150 mm

4
Intake muffler
Aluminum/paper/plastic heating-air intake

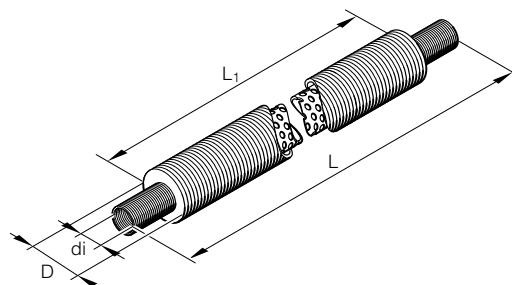

di = 75 mm, D = 110 mm, L = 600 mm, L1 = 300 mm

Airtronic	Airtronic M	Airtronic L	Air heater 8 L / V 7 S	Hydronic 4 / 5 KW	Hydronic M / M2	Hydronic L / L2	Order no.
~	~	~	~	~	~	~	10 2114 29 00 00
~	~	~	~	~	~	~	10 2114 31 00 00
~	~	~	~	~	~	~	10 2114 34 00 00
~	~	~	~	~	~	~	10 2114 37 00 00
~	~	~	~	~	~	~	10 2114 38 00 00
~	~	~	~	~	~	~	360 00 165
~	~	~	~	~	~	~	360 00 012
~	~	~	~	~	~	~	360 00 013
~	~	~	~	~	~	~	360 00 014
~	~	~	~	~	~	~	25 1226 89 15 00
~	~	~	~	~	~	~	25 1226 89 17 00
~	~	~	~	~	~	~	25 1226 89 56 00
~	~	~	~	~	~	~	330 00 072

7 | AIR LINES

5
Filter
Installation on air-intake side

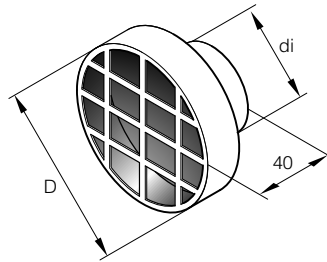

~ = Check regularly for dirt and clean if required.
Ensure that the protected intake area is protected.

di = 60 mm, D = 107 mm

Airtronic	Airtronic M	Airtronic L	Air heater 8 L / V 7 S	Hydronic 4 / 5 KW	Hydronic M / M2	Hydronic L / L2	Order no.
~							25 1688 89 05 00

10
Upright vent 30°
Rotatable, see Item 16 for fitting

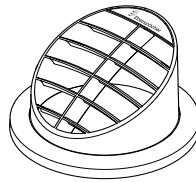

* available from May 2014

~ = Check connection diameter

* suitable for ø 50/60 mm fitting, black
* suitable for ø 50/60 mm fitting, white
* suitable for ø 75/90 mm fitting, black
* suitable for ø 75/90 mm fitting, white

							22 1000 01 00 56
							22 1000 01 00 57
							22 1000 01 00 60
							22 1000 01 00 61

10.1
Vent
Rotatable

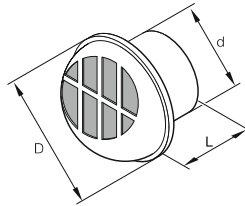

~ = Check connection diameter

d = 50 mm, D = 97 mm, L = 50 mm
d = 60 mm, D = 97 mm, L = 50 mm
d = 80 mm, D = 120 mm, L = 50 mm

							20 1575 80 08 00
							20 1577 89 06 00
							20 1282 22 00 00

11
Flat vent 30°
Rotatable, see Item 16 for fitting

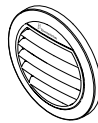

* available from May 2014

~ = Check connection diameter

* suitable for ø 50/60 mm fitting, black
* suitable for ø 50/60 mm fitting, white
* suitable for ø 75/90 mm fitting, black
* suitable for ø 75/90 mm fitting, white

							22 1000 01 00 44
							22 1000 01 00 45
							22 1000 01 00 52
							22 1000 01 00 53

11.1
Vent
Rotatable

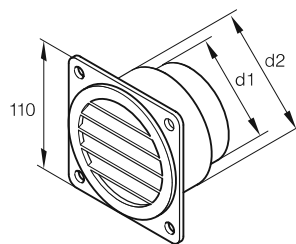

* with 4 stainless steel screws

~ = Check connection diameter

d1 = 60 mm, d2 = 100 mm, black
* d1 = 60 mm, d2 = 100 mm, white

							22 1000 01 07 00
							22 1000 01 11 00

7 | AIR LINES

12
Closable vent
Rotatable, see Item 16 for fitting

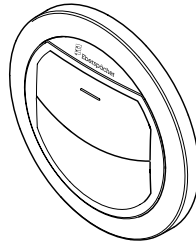

* available from May 2014

~ = Check connection diameter

- * suitable for \varnothing 50/60 mm fitting, black
- * suitable for \varnothing 50/60 mm fitting, white
- ~ suitable for \varnothing 75/90 mm fitting, black
- ~ suitable for \varnothing 75/90 mm fitting, white

Airtronic	Airtronic M	Airtronic L	Air heater 8 L / V 7 S	Hydronic 4 / 5 KW	Hydronic M / M2	Hydronic L / L2	Order no.
-----------	-------------	-------------	------------------------	-------------------	-----------------	-----------------	-----------

22 1000 01 00 72
22 1000 01 00 73
22 1000 01 00 76
22 1000 01 00 77

12.1
Round nozzle
With bladed shutter, closable
Suitable for a two-channel heating-air line only

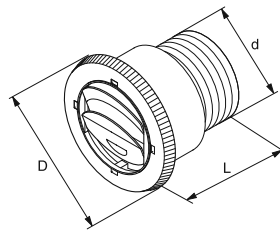

- d = 60 mm, D = 100 mm, L = 63 mm, black
- d = 60 mm, D = 100 mm, L = 63 mm, white

330 31 313
330 31 314

1

13
Flat vent 0°
Rotatable, see Item 16 for fitting

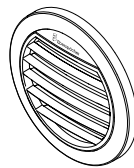

* available from May 2014

~ = Check connection diameter

- * suitable for \varnothing 50/60 mm fitting, black
- * suitable for \varnothing 50/60 mm fitting, white
- ~ suitable for \varnothing 75/90 mm fitting, black
- ~ suitable for \varnothing 75/90 mm fitting, white

22 1000 01 00 40
22 1000 01 00 41
22 1000 01 00 48
22 1000 01 00 49

2

3

4

5

13.1
Grille

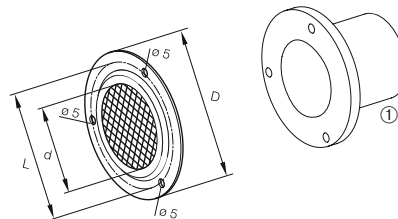

- * D = 93 mm, L = 75, d = 60 mm
Plastic

22 1000 01 00 01

* suitable for Item 18

6

7

8

9

14
Upright vent 90°
Rotatable, see Item 16 for fitting

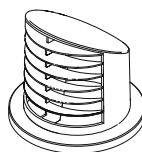

- * suitable for \varnothing 50/60 mm fitting, black
- * suitable for \varnothing 50/60 mm fitting, white
- ~ suitable for \varnothing 75/90 mm fitting, black
- ~ suitable for \varnothing 75/90 mm fitting, white

22 1000 01 00 64
22 1000 01 00 65
22 1000 01 00 68
22 1000 01 00 69

* available from May 2014

~ = Check connection diameter

10

11

12

13

7 | AIR LINES

15 Air control element

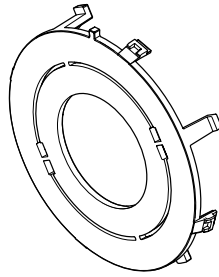

* for fitting, Item 16, order no. 22 1000 01 00 35 (available from May 2014)
 ** for fitting, Item 16, order no. 22 1000 01 00 36
 *** for fitting, Item 16, order no. 22 1000 01 00 37

* Plastic, \varnothing 60 mm
 ** Plastic, \varnothing 75 mm
 *** Plastic, \varnothing 90 mm

Airtronic	Airtronic M	Airtronic L	Air heater 8 L / V 7 S	Hydronic 4 / 5 KW	Hydronic M / M2	Hydronic L / L2	Order no.
■	■	■	~				22 1000 01 00 79
■	■	■	~				22 1000 01 00 80
■	■	■	~				22 1000 01 00 81

16 Fitting

For vents, Items 10, 11, 12, 13 and 14

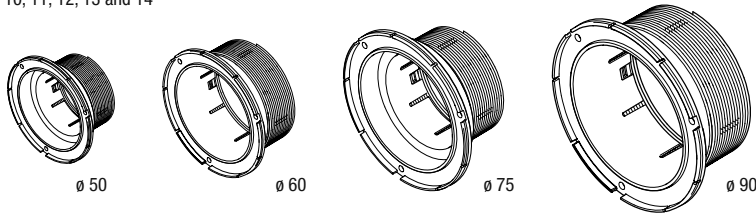

* available from May 2014

~ = Check connection diameter

* \varnothing 50 mm, black
 * \varnothing 60 mm, black
 \varnothing 75 mm, black
 \varnothing 90 mm, black

■	■	■	~				22 1000 01 00 34
■	■	■	~				22 1000 01 00 35
■	■	■	~				22 1000 01 00 36
■	■	■	~				22 1000 01 00 37

17 Grille, heater

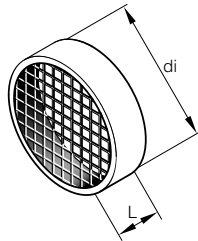

~ = Check connection diameter

di = 60 mm, L = 20 mm
 di = 75 mm, L = 22 mm
 di = 90 mm, L = 24 mm
 di = 100 mm, L = 22 mm

■							25 1688 80 06 00
■	~						25 1552 05 01 00
■	■	~					25 1729 80 00 01
~	~	■					25 1226 89 44 00

18 Hose fitting

Suitable for grille, Item 13.1*

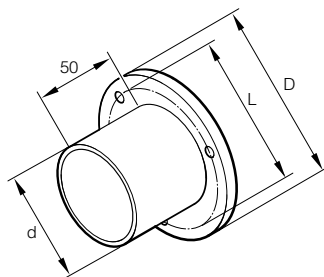

* D = 93 mm

~ = Check connection diameter

d = 50 mm, D = 97 mm, L = 75
 d = 60 mm, D = 97 mm, L = 75

~							20 1575 80 08 01
■	~						20 1577 89 06 01

7 | AIR LINES

21
Scoop

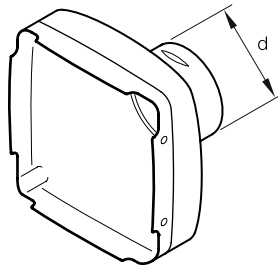

d = 60 mm
d = 75 mm
d = 75 mm
d = 90 mm

Airtronic	Airtronic M	Airtronic L	Air heater 8 L / V 7 S	Hydronic 4 / 5 KW	Hydronic M / M2	Hydronic L / L2	Order no.
-----------	-------------	-------------	------------------------	-------------------	-----------------	-----------------	-----------

22 1000 01 00 16
22 1000 01 00 17
22 1000 01 00 18
22 1000 01 00 19

22
Scoop

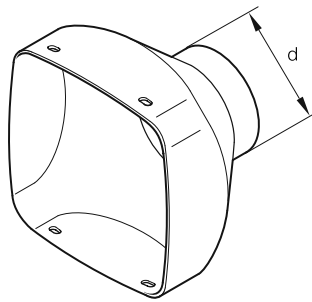

d = 90 mm

							25 1729 01 09 00
--	--	--	--	--	--	--	------------------

1

30
Ball-shaped scoop

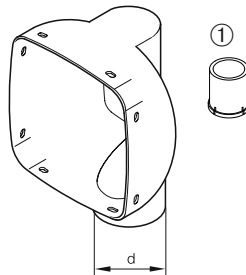

d = 90 mm

2

3

4

①
Connection fitting, see Item 31

5

							25 1729 89 10 00
--	--	--	--	--	--	--	------------------

6

31
Connection fitting
Ball-shaped scoop, Item 30/32

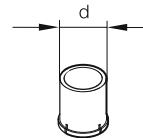

d = 25 mm
d = 50 mm

7

8

9

							20 1575 89 00 15
							22 1000 01 00 04

10

32
Ball-shaped scoop

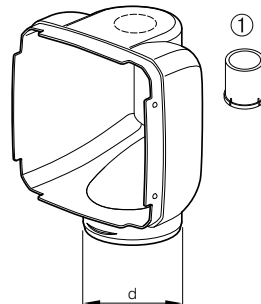

d = 60 mm
d = 75 mm
* d = 75 mm
* d = 90 mm

11

Caution! Make sure the line guide number is not too high

12

①
Connection fitting, see Item 31

13

* Cannot be used with the Airtronic D4 Plus

							22 1000 01 00 20
							22 1000 01 00 28
							22 1000 01 00 22
							22 1000 01 00 23

7 | AIR LINES

33
Pipe elbow, 90°

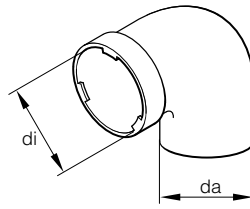

di = 60 mm, da = 60 mm
di = 75 mm, da = 75 mm

Airtronic	Airtronic M	Airtronic L	Air heater 8 L / V 7 S	Hydronic 4 / 5 KW	Hydronic M / M2	Hydronic L / L2	Order no.

25 1688 89 00 01
25 1482 89 00 05

34
Ring

Protective grille (Item 17), di = 90 mm.
Can be used as a transition piece – remove grille.

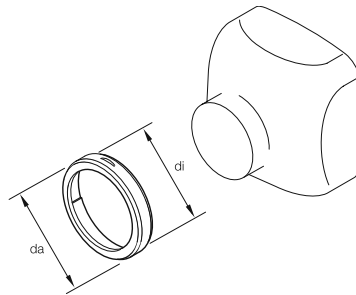

di = 60 mm, da = 75 mm
di = 75 mm, da = 90 mm
di = 90 mm, da = 100 mm

Airtronic	Airtronic M	Airtronic L	Air heater 8 L / V 7 S	Hydronic 4 / 5 KW	Hydronic M / M2	Hydronic L / L2	Order no.

22 1000 01 00 08
25 1822 89 00 01
20 1607 80 00 01

35
T-junction

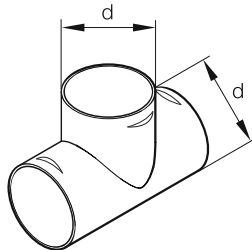

Metal, d = 50 mm
Plastic, d = 60 mm
Plastic, d = 75 mm
Plastic, d = 90 mm
Metal, d = 100 mm

Airtronic	Airtronic M	Airtronic L	Air heater 8 L / V 7 S	Hydronic 4 / 5 KW	Hydronic M / M2	Hydronic L / L2	Order no.

20 1575 89 18 00
25 1688 89 00 02
22 1000 01 00 27
22 1000 01 00 26
20 1667 89 03 00

~ = Check connection diameter

40
Butterfly valve

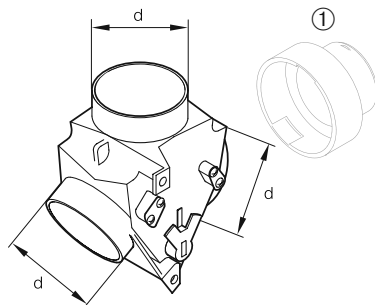

d = 60 mm
d = 90 mm

Airtronic	Airtronic M	Airtronic L	Air heater 8 L / V 7 S	Hydronic 4 / 5 KW	Hydronic M / M2	Hydronic L / L2	Order no.

330 00 174
330 00 175

①
Transition piece, see Item 45

~ = Check connection diameter

- 1
- 2
- 3
- 4
- 5
- 6
- 7
- 8
- 9
- 10
- 11
- 12
- 13

7 | AIR LINES

41
Control unit
For butterfly valve, Item 40, 2 m long

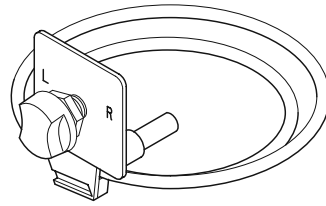

Airtronic	Airtronic M	Airtronic L	Air heater 8 L / V / 7 S	Hydronic 4 / 5 KW	Hydronic M / M2	Hydronic L / L2	Order no.
■	■	■	■				22 1000 01 03 00

42.1
Y-junction

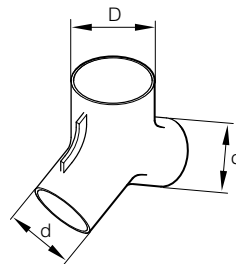

Plastic, D = 60 mm, d = 50 mm
Metal, D = 75 mm, d = 50 mm

~ = Check connection diameter

■	■	~					25 1688 89 00 03 25 1482 80 08 00
---	---	---	--	--	--	--	--------------------------------------

42
Y-junction

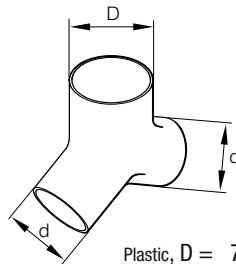

Plastic, D = 75 mm, d = 60 mm
Plastic, D = 90 mm, d = 60 mm
Plastic, D = 90 mm, d = 75 mm

~ = Check connection diameter

■	■	~					22 1000 01 00 82 22 1000 01 00 83 22 1000 01 00 84
---	---	---	--	--	--	--	--

43
Y-junction

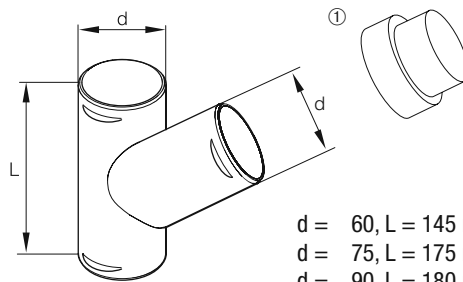

d = 60, L = 145 mm
d = 75, L = 175 mm
d = 90, L = 180 mm
d = 100, L = 230 mm

①
Transition piece, see Item 45

~ = Check connection diameter

■	■	~	~	~	~	■	25 1774 89 00 05 25 1226 89 00 44 22 1000 01 00 21 25 1226 89 00 45
---	---	---	---	---	---	---	--

44
Hose connector fitting

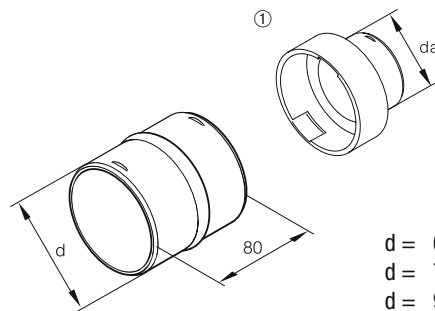

d = 60 mm
d = 75 mm
d = 90 mm
d = 100 mm

①
Transition piece, see Item 45

~ = Check connection diameter

■	~	~	~	~	■		22 1000 01 00 05 22 1000 01 00 06 22 1000 01 00 24 22 1000 01 00 07
---	---	---	---	---	---	--	--

7 | AIR LINES

45
Transition piece
For Item 40, 43 and 44

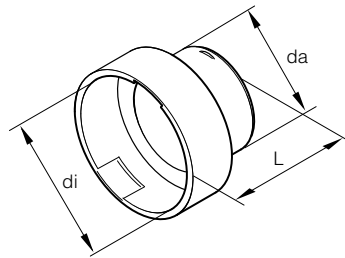

- di = 75 mm, da = 50 mm, L = 50 mm
- di = 75 mm, da = 60 mm, L = 45 mm
- di = 90 mm, da = 75 mm, L = 45 mm
- di = 100 mm, da = 50 mm, L = 62 mm
- di = 100 mm, da = 60 mm, L = 57 mm
- di = 100 mm, da = 75 mm, L = 50 mm
- di = 100 mm, da = 90 mm, L = 42 mm

~ = Check connection diameter

46
Adapter

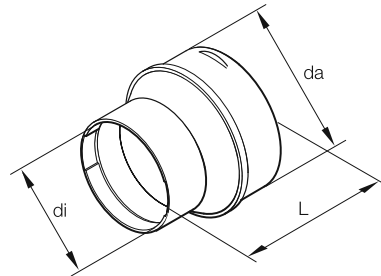

di = 60 mm, da = 75 mm, L = 40.5 mm

~ = Check connection diameter

47
Adapter
Metal

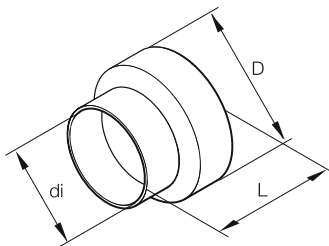

di = 90 mm, D = 100 mm, L = 46 mm

~ = Check connection diameter

48
Sleeve/transition piece

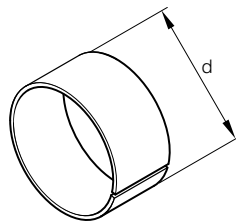

d = 90 mm/100 mm

~ = Check connection diameter

Airtronic	Airtronic M	Airtronic L	Air heater 8 L / V 7 S	Hydronic 4 / 5 KW	Hydronic M / M2	Hydronic L / L2	Order no.
■	■	~					25 1226 89 00 46
■	■	~					25 1226 89 00 50
~	■	■	~				22 1000 01 00 12
~	~	~	■				25 1226 89 00 48
~	~	~	■				25 1226 89 00 51
~	~	~	■				25 1226 89 00 47
~	~	~	■				25 1226 89 00 49
							25 1688 89 00 10
							20 1462 89 00 01
							20 1607 80 00 01

- 1
- 2
- 3
- 4
- 5
- 6
- 7
- 8
- 9
- 10
- 11
- 12
- 13

8 | FUEL LINES

GENERAL INFORMATION:

- Protect fuel lines, filters and metering pumps from impermissible heat levels; do not install near control dampers and exhaust pipes.
- Take the rear axle suspension into account when installing fuel lines, fuel filters and metering pumps near the rear axle.
- When cutting fuel hoses and pipes, be sure to use a sharp knife.
- Cut surfaces must have no dents or burrs.
- Please also refer to the safety information on this section in the heater documentation.

1

2

3

4

5

6

7

8

9

10

11

12

13

8 | FUEL LINES

Stand pipe
For cars with an inner tank pump

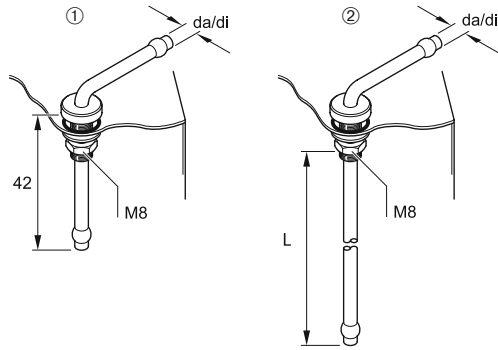

- ① da = 4 mm, di = 2 mm
- ② da = 4 mm, di = 2 mm, L = 295 mm

Airtronic	Airtronic M	Airtronic L	Air heater 8 L / V 7 S	Hydronic 4 / 5 KW	Hydronic M / M2	Hydronic L / L2	Order no.
-----------	-------------	-------------	------------------------	-------------------	-----------------	-----------------	-----------

							22 1000 20 15 00
							22 1000 20 16 00

Tank connection with return
For commercial vehicles

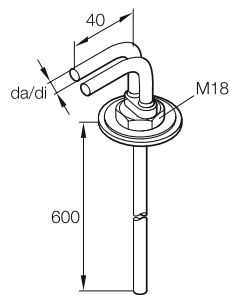

da = 6 mm, di = 4 mm

							25 1226 89 40 00
--	--	--	--	--	--	--	------------------

Stand pipe
For commercial vehicles

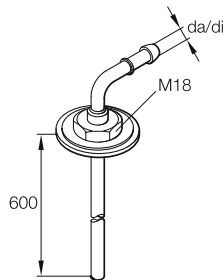

- da = 6 mm, di = 2 mm
- da = 6 mm, di = 4 mm

							25 1226 89 50 00
							25 1156 30 00 00

Kit – fuel lines for E85
Only for Hydronic 2–B5 S

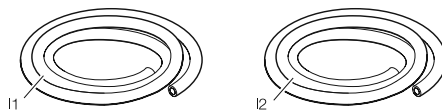

I1 = Ø 4x1.25 pipe; L = 6 m, black/I2 = Ø 4x1 pipe; L = 2 m, black

							22 1000 20 31 00
--	--	--	--	--	--	--	------------------

Tank connection kit
For cars with an inner tank pump

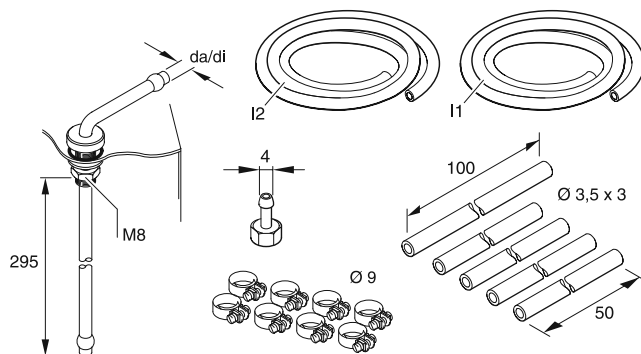

I1 = Ø 4x1.25 pipe; L = 6 m/I2 = Ø 4x1 pipe; L = 6 m/da = 4 mm, di = 2 mm

							22 1000 20 13 00
--	--	--	--	--	--	--	------------------

8 | FUEL LINES

Fuel supply kit
For installation in the tank ventilation hose

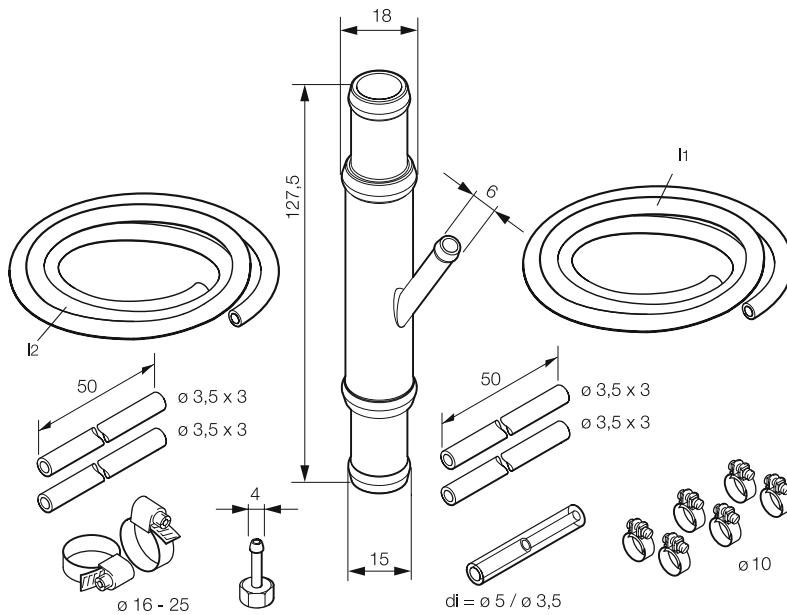

I1 = \varnothing 4x1 steel pipe, L = 1 m / I2 = \varnothing 4x1 plastic pipe, L = 2 m

Airtronic	Airtronic M	Airtronic L	Air heater 8 L / V 7 S	Hydronic 4 / 5 KW	Hydronic M / M2	Hydronic L / L2	Order no.
							22 1000 20 06 00
							22 1000 20 17 00
							360 75 300
							360 75 400
							360 75 350
							360 75 401
							360 75 402
							360 75 404

1

Fuel supply kit
Tank extraction feed line

2

3

4

5

6

7

8

9

Fuel hose (linear m)

10

11

12

13

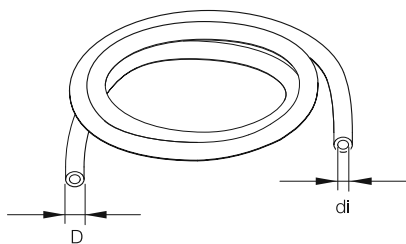

- di = 3.5 mm, D = 9.50 mm
- * di = 3.5 mm, D = 9.50 mm
- di = 5.0 mm, D = 11.0 mm
- * di = 5.0 mm, D = 11.0 mm
- * di = 7.5 mm, D = 13.5 mm
- * di = 9.0 mm, D = 15.0 mm

* PME-compatible

8 | FUEL LINES

Fuel supply kit
For installing fuel line
in boat engine compartments

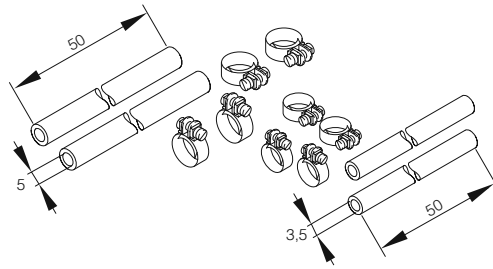

Fire-resistant hose according to DIN EN ISO 7840

Airtronic	Airtronic M	Airtronic L	Air heater 8 L / V 7 S	Hydronic 4 / 5 KW	Hydronic M / M2	Hydronic L / L2	Order no.
-----------	-------------	-------------	------------------------	-------------------	-----------------	-----------------	-----------

22 1000 20 10 00

Fuel hose 105° elbow
PME-compatible

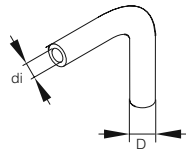

di = 3.5 mm, D = 9.5 mm

25 1888 80 01 01

Adapter

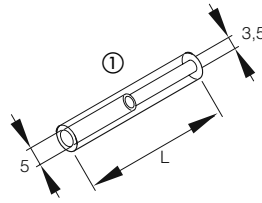

L = 40 mm

25 1888 80 01 02

Transition piece 105° elbow
PME-compatible

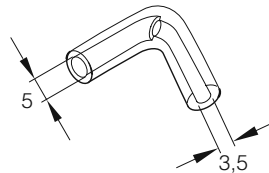

25 2110 05 03 01

Transition piece for fuel pipes

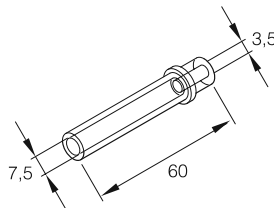

22 1000 20 30 00

Fuel pipe (linear m)
Plastic

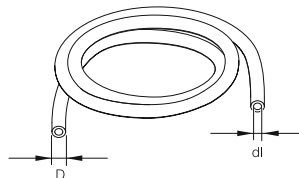

- natural-colored, di = 1.5 mm , D = 4 mm
- natural-colored, di = 2 mm , D = 4 mm
- ethanol resistant, di = 1.5 mm , D = 4 mm
- ethanol resistant, di = 2 mm , D = 4 mm
- blue, di = 2 mm , D = 4 mm
- black, di = 2 mm , D = 6 mm
- blue, di = 4 mm , D = 6 mm

890 31 118
890 31 055
890 31 138
890 31 139
890 31 054
890 31 125
890 31 101

8 | FUEL LINES

Foam rubber hose (linear m)
Chafing protection and soundproofing for fuel pipe

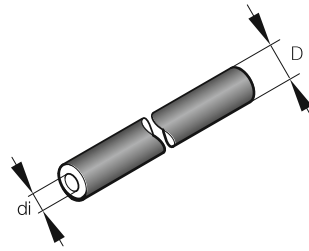

di = 5 mm, D = 11 mm

Heat protection hose
For fuel pipe
Aluminum clad with fiberglass cloth
Also suitable for electrical cabling

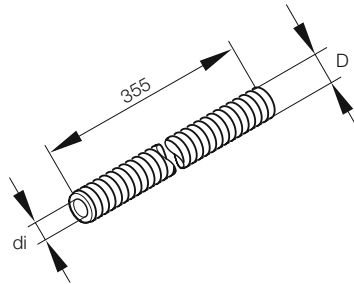

di = 10 mm, D = 13 mm

Reinforcing sleeve
Brass, for plastic fuel pipes
10 per pack

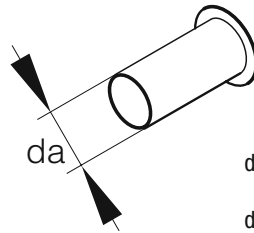

da = 4 mm
for 6x1 pipe
da = 6 mm
for 8x1 pipe
da = 8 mm
for 10x1 pipe

Hose nipple
Straight, for M 10 x 1 union nut

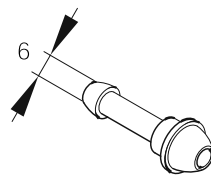

Ring fitting with hose connection

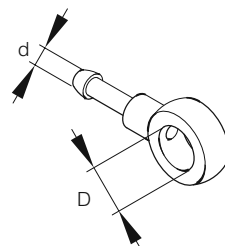

d = 5 mm, D = 8 mm
d = 5 mm, D = 14 mm

Airtronic	Airtronic M	Airtronic L	Air heater 8 L / V 7 S	Hydronic 4 / 5 KW	Hydronic M / M2	Hydronic L / L2	Order no.
■	■	■	■	■	■	■	360 75 200
■	■	■	■	■	■	■	360 00 183
■	■	■	■	■	■	■	22 1000 20 01 00
■	■	■	■	■	■	■	22 1000 20 02 00
■	■	■	■	■	■	■	22 1000 20 03 00
■	■	■	■	■	■	■	25 1351 88 01 01
■	■	■	■	■	■	■	25 1352 88 00 05
■	■	■	■	■	■	■	25 1373 88 03 00

- 1
- 2
- 3
- 4
- 5
- 6
- 7
- 8
- 9
- 10
- 11
- 12
- 13

8 | FUEL LINES

T-piece
Plastic

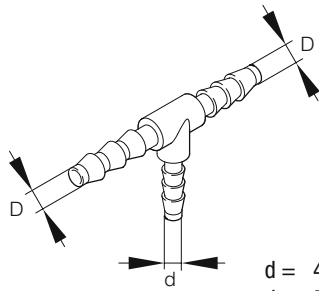

- d = 4 mm, D = 8 mm
- d = 5 mm, D = 5 mm
- d = 6 mm, D = 6 mm
- d = 6 mm, D = 8 mm
- d = 6 mm, D = 10 mm
- d = 6 mm, D = 12 mm

~ = Check hose diameter

Fuel filter with paper insert
Plastic/installation in front of fuel circulation pump

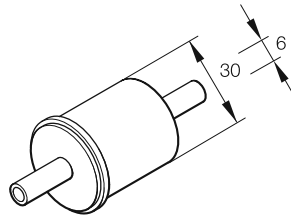

~ = Important! Fuel filter suitable for use with fuel circulation pump only

Fuel filter with metal strainer
Plastic/for metering pumps with cup strainer

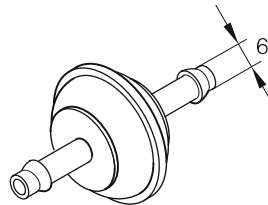

Check valve

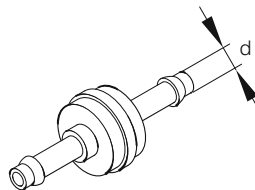

- d = 6 mm
- d = 8 mm

Airtronic	Airtronic M	Airtronic L	Air heater 8 L / V 7 S	Hydronic 4 / 5 KW	Hydronic M / M2	Hydronic L / L2	Order no.
~	~	~	~	~	~	~	262 31 155
~	~	~	~	~	~	~	262 31 149
~	~	~	~	~	~	~	262 31 150
~	~	~	~	~	~	~	262 31 151
~	~	~	~	~	~	~	262 31 152
~	~	~	~	~	~	~	262 31 153
~	~	~	~	~	~	~	25 1156 20 00 09
~	~	~	~	~	~	~	25 1226 89 00 37
■	■	■	■	■	■	■	244 31 060
■	■	■	■	■	■	■	244 31 061

- 1
- 2
- 3
- 4
- 5
- 6
- 7
- 8
- 9
- 10
- 11
- 12
- 13

8 | FUEL LINES

Pressure reducer
 With cup strainer and hose fitting
 Input pressure 0.2–4 bar
 Control pressure min. 50 mbar, max. 150 mbar

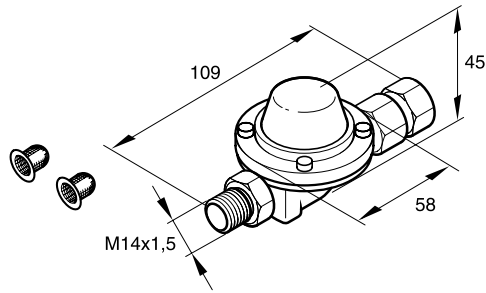

Airtronic	Airtronic M	Airtronic L	Air heater 8 L / V 7 S	Hydronic 4 / 5 KW	Hydronic M / M2	Hydronic L / L2	Order no.
■	■	■		■			22 1000 20 08 00

Complete fuel tank, 10 l
 Plastic

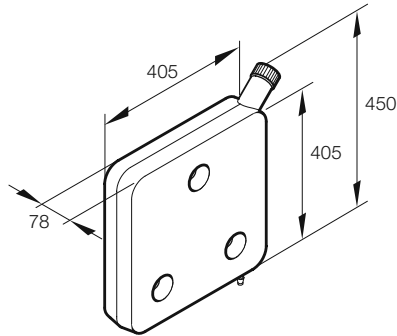

~ = Only suitable for diesel/bio-diesel (FAME)/heating oil

~	~	~	~	~	~	~	22 1000 20 28 00
---	---	---	---	---	---	---	------------------

Complete fuel tank, 10 l – single part
 Lid
 Plastic

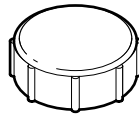

1

2

3

4

~	~	~	~	~	~	~	22 1000 20 22 00
---	---	---	---	---	---	---	------------------

Complete fuel tank, 10 l – single part
 Fuel strainer

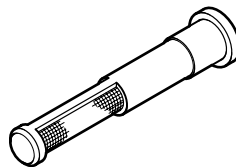

5

6

7

8

~	~	~	~	~	~	~	22 1000 20 28 03
---	---	---	---	---	---	---	------------------

Complete fuel tank, 10 l – single part
 Seal



9

10

11

12

13

~	~	~	~	~	~	~	22 1000 20 28 04
---	---	---	---	---	---	---	------------------

9 | ELECTRICAL PARTS/TESTING EQUIPMENT

GENERAL INFORMATION:

- Using a timer you can manually or automatically switch on the heater at a preset time (pre-heating mode).
- Always make sure that a heater can run on, even if the vehicle's whole electrical system can be shut down with a battery main switch (i.e. via an additional electrical connection or clear instruction that the battery main switch should be open when the heater is running with a flame).
- The rule of thumb for the electrical power supply is: charging time = heating time.
- In certain circumstances, heaters in motorhomes or commercial vehicles are operated for longer sustained periods. In these cases, the on-board energy resources need to be monitored.
- For more detailed information, see technical description and installation instructions.
- Please also refer to the safety information on this section in the heater documentation.

1

2

3

4

5

6

7

8

9

10

11

12

13

EasyStart Remote+
Remote control

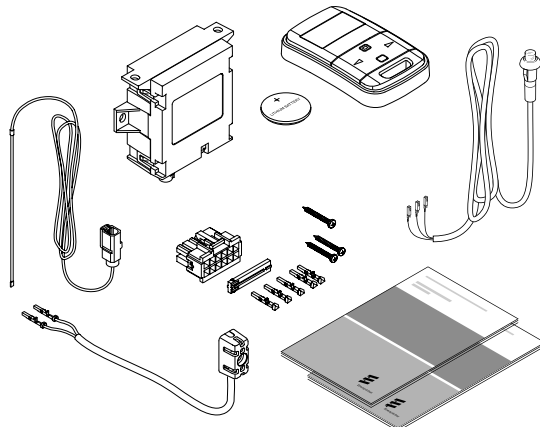

12 V/24 V

Airtronic	Airtronic M	Airtronic L	Air heater 8 L / V / 7 S	Hydronic 4 / 5 KW	Hydronic M / M2	Hydronic L / L2	Order no.
-----------	-------------	-------------	--------------------------	-------------------	-----------------	-----------------	-----------

22 1000 34 17 00

EasyStart Remote
Remote control

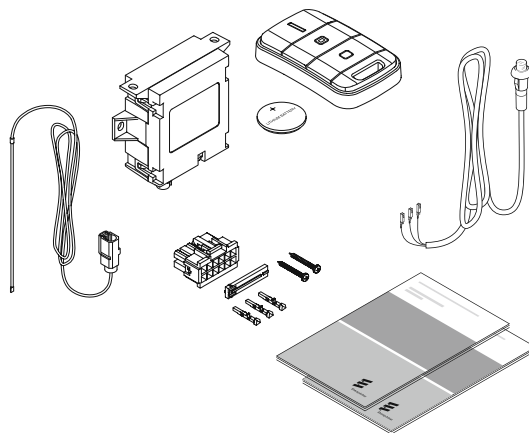

12 V/24 V

22 1000 34 23 00

EasyStart Timer

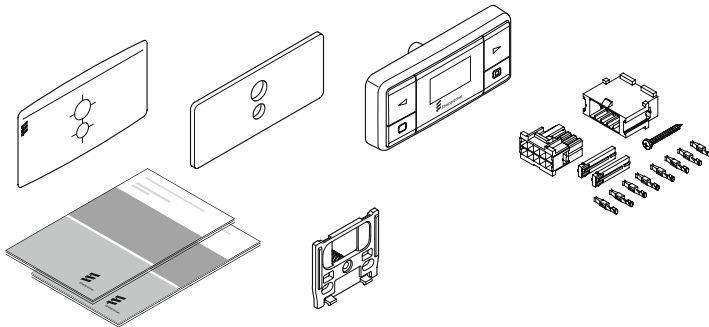

Timer trim for EasyStart Timer, see page 125

~ = Heater operation only, no diagnostics

12 V/24 V

22 1000 34 15 00

EasyStart Select

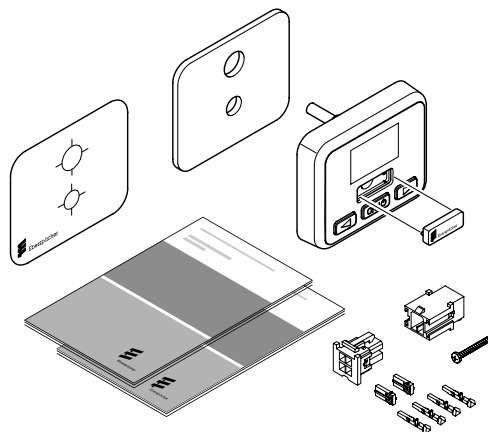

12 V/24 V

22 1000 34 13 00

- 1
- 2
- 3
- 4
- 5
- 6
- 7
- 8
- 9
- 10
- 11
- 12
- 13

EasyStart Call
Telephone radio remote control

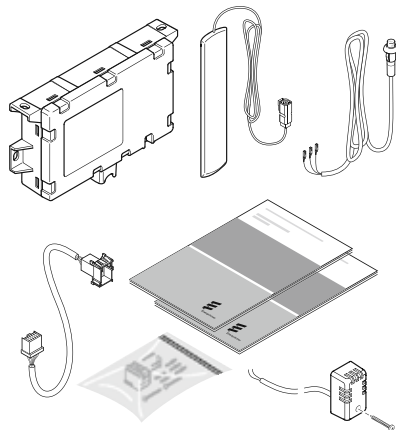

12 V/24 V

Airtronic	Airtronic M	Airtronic L	Air heater 8 L / V 7 S	Hydronic 4 / 5 KW	Hydronic M / M2	Hydronic L / L2	Order no.
-----------	-------------	-------------	------------------------	-------------------	-----------------	-----------------	-----------

22 1000 34 01 00

EasyStart Remote+ – single part
Mobile part

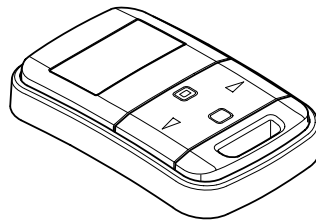

12 V/24 V

22 1000 34 18 00

EasyStart Remote+ – single part
Fixed part

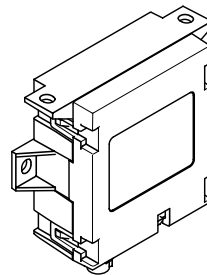

12 V/24 V

22 1000 34 19 00

EasyStart Remote+ – single part
Sensor – interior temperature, display

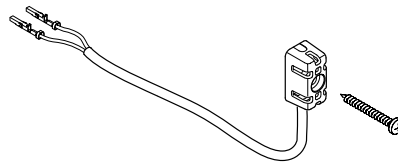

22 1000 34 22 00

EasyStart Remote – single part
Mobile part

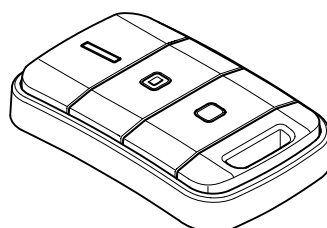

12 V/24 V

22 1000 34 24 00

- 1
- 2
- 3
- 4
- 5
- 6
- 7
- 8
- 9
- 10
- 11
- 12
- 13

9 | ELECTRICAL PARTS

EasyStart Remote – single part
Fixed part

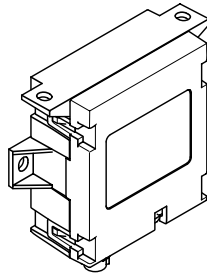

12 V/24 V

Airtronic	Airtronic M	Airtronic L	Air heater 8 L / V / 7 S	Hydronic 4 / 5 KW	Hydronic M / M2	Hydronic L / L2	Order no.
-----------	-------------	-------------	--------------------------	-------------------	-----------------	-----------------	-----------

22 1000 34 25 00

EasyStart Remote+ / EasyStart Remote – single part
Cover for battery compartment

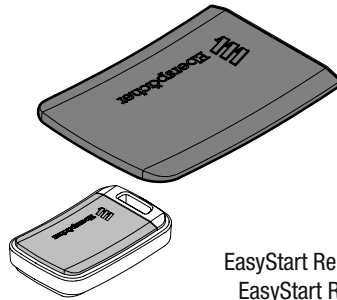

EasyStart Remote+
EasyStart Remote

							22 1000 34 18 01
							22 1000 34 24 01

EasyStart Remote+ / EasyStart Remote – single part
Antenna

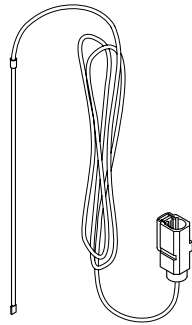

							22 1000 34 21 00
--	--	--	--	--	--	--	------------------

EasyStart Remote+ / EasyStart Remote – single part
Button

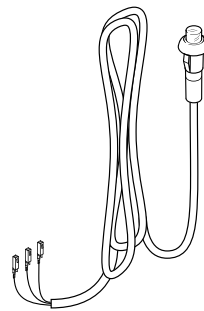

							22 1000 34 20 00
--	--	--	--	--	--	--	------------------

EasyStart Call / EasyStart Remote+ / EasyStart Remote / EasyStart Timer / EasyStart Select – single part
Electrical connection parts

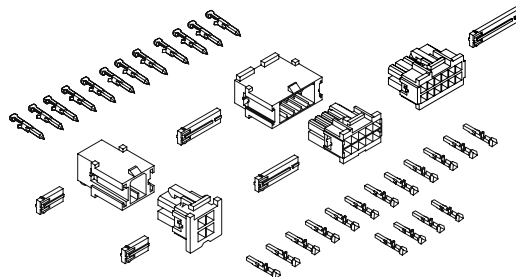

							22 1000 34 26 00
--	--	--	--	--	--	--	------------------

EasyStart Select – single part
Plugs

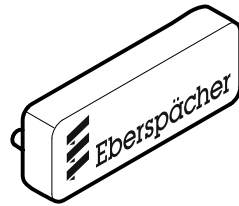

Airtronic	Airtronic M	Airtronic L	Air heater 8 L / V 7 S	Hydronic 4 / 5 KW	Hydronic M / M2	Hydronic L / L2	Order no.
							22 1000 34 13 01

EasyStart Call – single part
Slide antenna

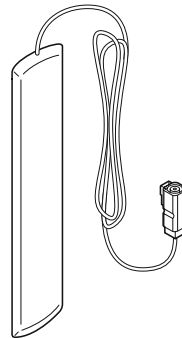

							22 1000 34 03 00
--	--	--	--	--	--	--	------------------

EasyStart Call – single part
Button

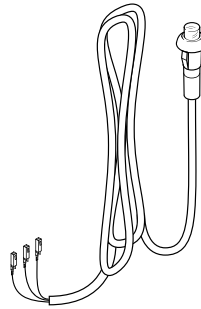

							22 1000 34 04 00
--	--	--	--	--	--	--	------------------

EasyStart Call – single part
Temperature sensor

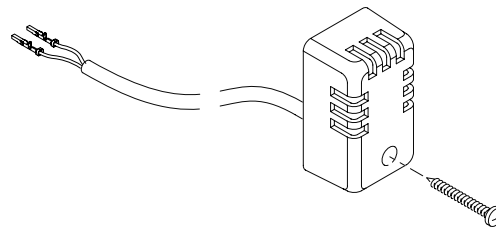

							22 1000 34 09 00
--	--	--	--	--	--	--	------------------

EasyStart Call, EasyStart Remote+/EasyStart Remote/EasyStart Timer – single part
Adapter cable

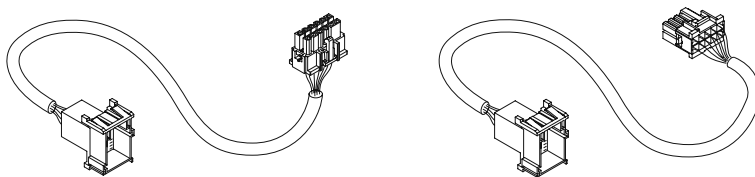

EasyStart Remote/EasyStart Remote+/EasyStart Call (12-pin)
EasyStart Timer (10-pin)

							22 1000 34 08 00
							22 1000 34 45 00

- 1
- 2
- 3
- 4
- 5
- 6
- 7
- 8
- 9
- 10
- 11
- 12
- 13

9 | ELECTRICAL PARTS

EasyStart R+ – single part
Mobile part



Spare part for 22 1000 32 80 00

12 V/24 V

Airtronic	Airtronic M	Airtronic L	Air heater 8 L / V / 7 S	Hydronic 4 / 5 KW	Hydronic M / M2	Hydronic L / L2	Order no.
-----------	-------------	-------------	--------------------------	-------------------	-----------------	-----------------	-----------

			~				22 1000 32 81 00
--	--	--	---	--	--	--	------------------

EasyStart R+ – single part
Fixed part

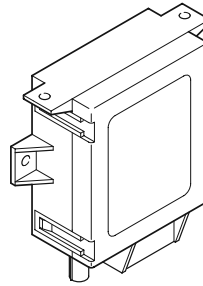

Spare part for 22 1000 32 80 00

			~				22 1000 32 82 00
--	--	--	---	--	--	--	------------------

1 EasyStart R – single part

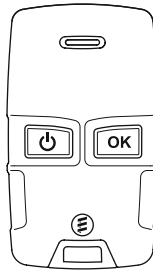

2

3

4

5

Spare part for 22 1000 32 85 00

12 V/24 V

			~				22 1000 32 86 00
--	--	--	---	--	--	--	------------------

6 EasyStart R – single part
Fixed part

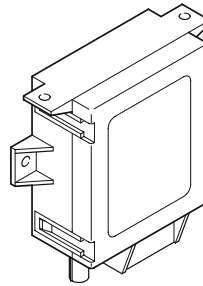

7

8

9

Spare part for 22 1000 32 85 00

			~				22 1000 32 87 00
--	--	--	---	--	--	--	------------------

11 EasyStart R+/EasyStart R – single part
Cover for battery compartment



12

13

Spare part for 22 1000 32 80 00 and 22 1000 32 85 00

			~				22 1000 32 91 00
--	--	--	---	--	--	--	------------------

9 | ELECTRICAL PARTS

EasyStart R+/EasyStart R – single part
Antenna

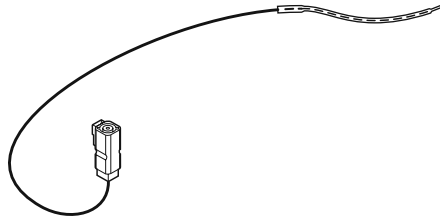

Spare part for 22 1000 32 80 00 and 22 1000 32 85 00

Airtronic	Airtronic M	Airtronic L	Air heater 8 L / V 7 S	Hydronic 4 / 5 KW	Hydronic M / M2	Hydronic L / L2	Order no.
-----------	-------------	-------------	------------------------	-------------------	-----------------	-----------------	-----------

							22 1000 32 83 00
--	--	--	--	--	--	--	------------------

EasyStart R+/EasyStart R – single part
Electrical connection parts

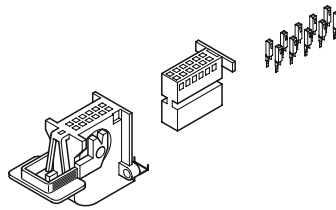

Spare part for 22 1000 32 80 00 and 22 1000 32 85 00

							22 1000 32 90 00
--	--	--	--	--	--	--	------------------

EasyStart R+/EasyStart R/EasyStart T – single part
Button

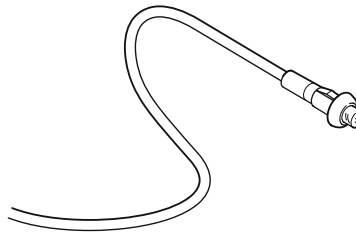

Spare part for 22 1000 32 80 00, 22 1000 32 85 00 and 22 1000 32 88 00

							22 1000 32 84 00
--	--	--	--	--	--	--	------------------

EasyStart R+/EasyStart R/EasyStart T – single part
Electrical connection parts

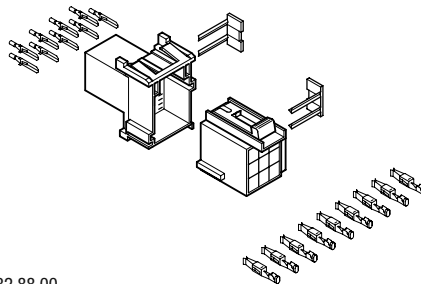

Spare part for 22 1000 32 80 00, 22 1000 32 85 00 and 22 1000 32 88 00

							22 1000 32 92 00
--	--	--	--	--	--	--	------------------

EasyStart R+/EasyStart T – single part
Sensor – interior temperature, display

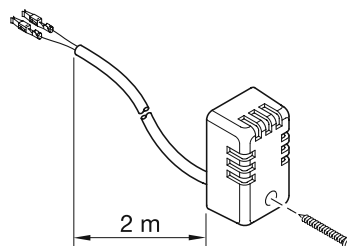

Spare part for 22 1000 32 80 00 and 22 1000 32 88 00

							22 1000 32 97 00
--	--	--	--	--	--	--	------------------

- 1
- 2
- 3
- 4
- 5
- 6
- 7
- 8
- 9
- 10
- 11
- 12
- 13

9 | ELECTRICAL PARTS

Calltronic – single part
Slide antenna

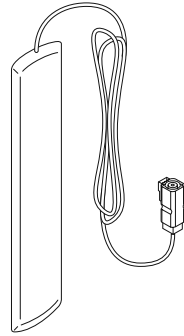

Airtronic	Airtronic M	Airtronic L	Air heater 8 L / V 7 S	Hydronic 4 / 5 KW	Hydronic M / M2	Hydronic L / L2	Order no.
-----------	-------------	-------------	------------------------	-------------------	-----------------	-----------------	-----------

							22 1000 33 63 00
--	--	--	--	--	--	--	------------------

Calltronic – single part
Button

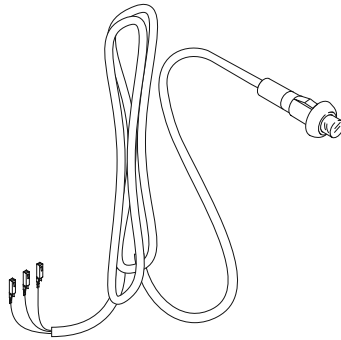

							22 1000 33 62 00
--	--	--	--	--	--	--	------------------

1 Calltronic I – single part
Slide antenna

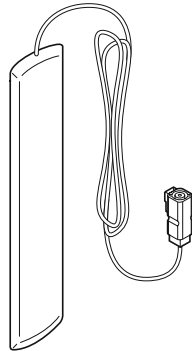

							22 1000 33 84 00
--	--	--	--	--	--	--	------------------

6 Calltronic I – single part
Button

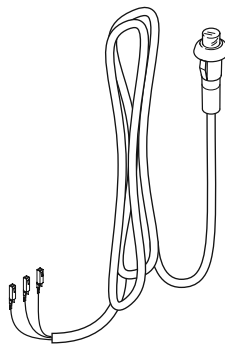

							22 1000 33 85 00
--	--	--	--	--	--	--	------------------

9 | ELECTRICAL PARTS

Mini-controller – single part

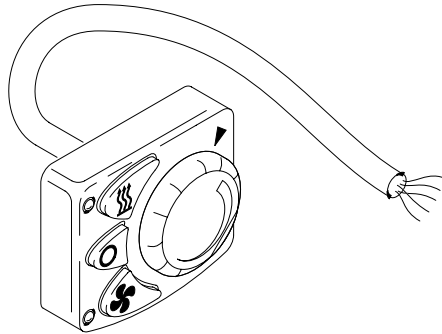

Airtronic	Airtronic M	Airtronic L	Air heater 8 L / V 7 S	Hydronic 4 / 5 KW	Hydronic M / M2	Hydronic L / L2	Order no.
							22 1000 32 07 00

Control unit

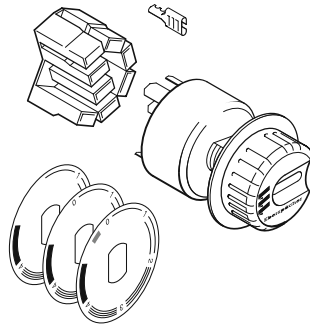

* with bushing connector housing and bushing connector
 ** without bushing connector housing and bushing connector /
 for air heater 8L only

~ = No ventilation, no diagnostic information.

* 12 V	~	~					25 1895 71 00 00
* 24 V	~	~					25 1896 71 00 00
** 12 V			~				25 1767 71 00 00
** 24 V			~				25 1768 71 00 00

Control unit – single part
 7-pin bushing connector housing

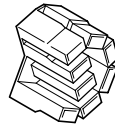

							206 31 282
--	--	--	--	--	--	--	------------

Control unit – single part
 Bushing connector

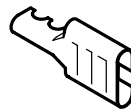

	~	~					206 36 151
--	---	---	--	--	--	--	------------

Heat/ventilation switch
 With bracket



							22 1000 31 89 00
--	--	--	--	--	--	--	------------------

9 | ELECTRICAL PARTS

Exterior and interior temperature control sensor
2 m cable harness

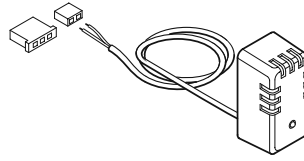

~ = Can be used with control unit

Cable harness/temperature sensor

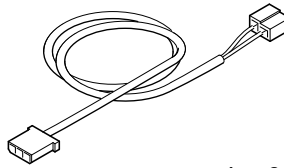

4 m, 2-pin
4 m, 3-pin

Additional heater installation kit
Only for Hydronic 2 in combination with EasyStart Remote+/Remote/Timer

Airtronic	Airtronic M	Airtronic L	Air heater 8 L / V 7 S	Hydronic 4 / 5 KW	Hydronic M / M2	Hydronic L / L2	Order no.
			~				25 1774 89 03 00
			~				25 1688 89 09 00
			~				25 1482 89 40 00
						~	24 8532 00 00 00

1

2

3

4

5

6

7

8

9

10

11

12

13

9 | ELECTRICAL PARTS

Voltage divider for fan control

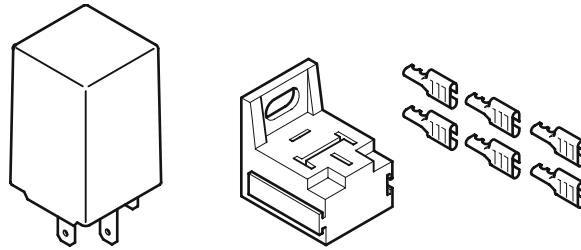

12 V/0–5 V
12 V/0–10 V

Airtronic	Airtronic M	Airtronic L	Air heater 8 L / V 7 S	Hydronic 4 / 5 KW	Hydronic M / M2	Hydronic L / L2	Order no.
-----------	-------------	-------------	------------------------	-------------------	-----------------	-----------------	-----------

22 1000 32 47 00
22 1000 32 48 00

Voltage divider for fan control – single part
Connector block

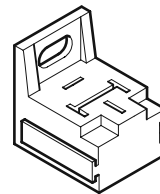

203 00 085

Voltage divider for fan control – single part
Bushing connector

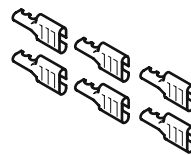

203 53 020

IPCU retrofit kit

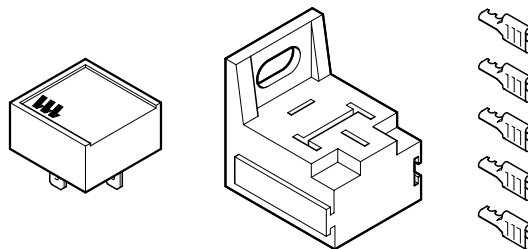

12 V

24 0273 00 00 00

~ = For customer-specific retrofit kits, see the Service Portal – EPRO/Accessories/Electrical parts

IPCU retrofit kit – single part
Relay

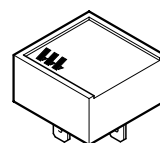

12 V

22 1000 32 73 00

- 1
- 2
- 3
- 4
- 5
- 6
- 7
- 8
- 9
- 10
- 11
- 12
- 13

9 | ELECTRICAL PARTS

IPCU adapter cable for EDiTH Basic

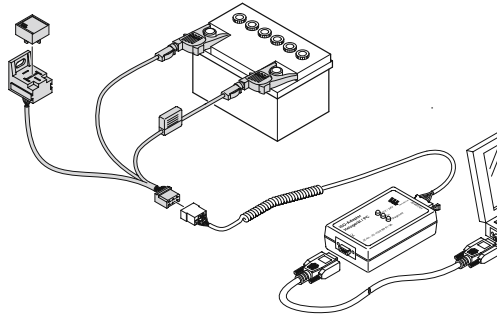

Airtronic	Airtronic M	Airtronic L	Air heater 8 L / V / 7 S	Hydronic 4 / 5 KW	Hydronic M / M2	Hydronic L / L2	Order no.
~	~	~	~	~	~	~	22 1000 32 74 00

IPCU expansion for EDiTH Expert

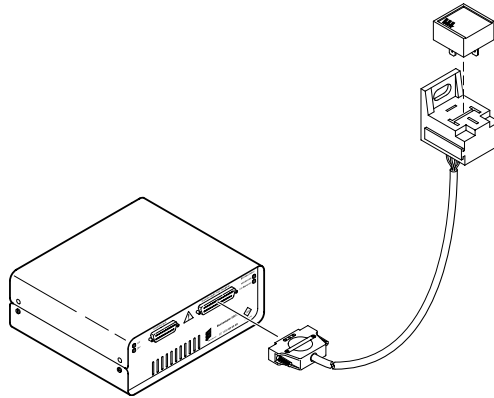

~	~	~	~	~	~	~	22 1000 32 76 00
---	---	---	---	---	---	---	------------------

Relay, changeover contact
Max. current consumption 40 A

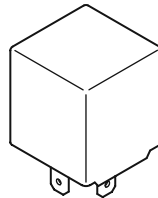

12 V	~	~	~	~	~	~	203 00 095
24 V	~	~	~	~	~	~	203 00 096

Triple fuse holder with pin
With 5 A, 15 A, 25 A fuses plus fastening parts

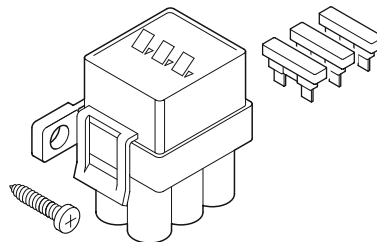

~	~	~	~	~	~	~	22 1000 31 06 00
---	---	---	---	---	---	---	------------------

9 | ELECTRICAL PARTS

Flat connector housing/Junior Timer
For mini-timer 22 1000 30 14 00

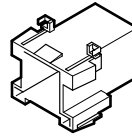

4-pin

Airtronic	Airtronic M	Airtronic L	Air heater 8 L / V 7 S	Hydronic 4 / 5 KW	Hydronic M / M2	Hydronic L / L2	Order no.
~	~	~	~	~	~	~	206 31 100

Flat connector housing/Junior Timer
For mini-timer 22 1000 32 35 00

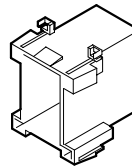

6-pin

~	~	~	~	~	~	~	206 31 106
---	---	---	---	---	---	---	------------

Flat connector housing/Junior Timer

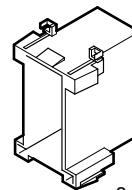

8-pin

~	~	~	~	~	~	~	206 31 101
---	---	---	---	---	---	---	------------

Flat connector
For flat connector housing/Junior Timer



0.5²-1.0²

~	~	~	~	~	~	~	206 36 018
---	---	---	---	---	---	---	------------

Bushing connector housing/Junior Timer
For mini-timer 22 1000 30 14 00

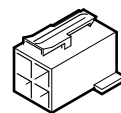

4-pin

~	~	~	~	~	~	~	206 31 296
---	---	---	---	---	---	---	------------

Bushing connector housing/Junior Timer
For mini-timer 22 1000 32 35 00

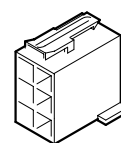

6-pin

~	~	~	~	~	~	~	206 31 297
---	---	---	---	---	---	---	------------

9 | ELECTRICAL PARTS

Bushing connector housing/Junior Timer

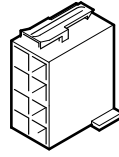

8-pin

Airtronic	Airtronic M	Airtronic L	Air heater 8 L / V 7 S	Hydronic 4 / 5 KW	Hydronic M / M2	Hydronic L / L2	Order no.
-----------	-------------	-------------	------------------------	-------------------	-----------------	-----------------	-----------

206 31 298

Bushing connector

For bushing connector housing/Junior Timer

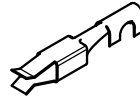

0.5²–1.0²
1.0²– 2.5²

~	~	~	~	~	~	~	206 73 052
~	~	~	~	~	~	~	206 73 053

Flat connector housing AMP 2.8

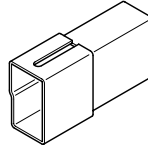

2-pin

~	~	~	~	~	~	~	206 31 018
---	---	---	---	---	---	---	------------

Flat connector

For flat connector housing AMP 2.8

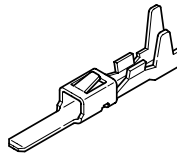

0.5²–1.0²
1.0²– 2.5²

~	~	~	~	~	~	~	206 73 001
~	~	~	~	~	~	~	206 52 151

Bushing connector housing AMP 2.8

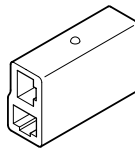

~	~	~	~	~	~	~	206 31 306
---	---	---	---	---	---	---	------------

Bushing connector

For bushing connector housing AMP 2.8

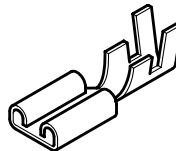

0.5²–1.0²
1.0²– 2.5²

~	~	~	~	~	~	~	206 73 039
~	~	~	~	~	~	~	206 36 161

8-pin bushing connector housing kit

For the Hydronic, with contacts and seals

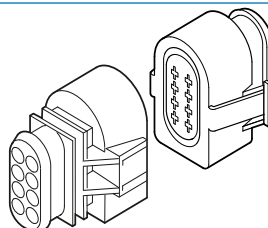

~	~	~	~	~	~	~	22 1000 30 10 21
---	---	---	---	---	---	---	------------------

9 | ELECTRICAL PARTS/TESTING EQUIPMENT

Connector housing kit
For metering pump, with contacts and seals

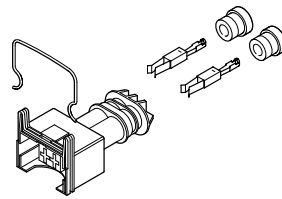

Airtronic	Airtronic M	Airtronic L	Air heater 8 L / V 7 S	Hydronic 4 / 5 KW	Hydronic M / M2	Hydronic L / L2	Order no.
-----------	-------------	-------------	------------------------	-------------------	-----------------	-----------------	-----------

22 1000 31 87 00

Control unit for cargo area heating, ADR/ADR99

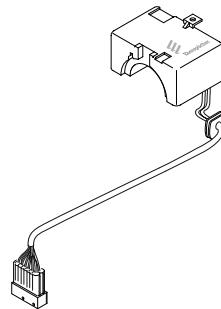

12 V
12 V
24 V
24 V
* 24 V
Retrofit kit, 24 V

22 5101 00 30 08
22 5101 00 30 09
22 5102 00 10 04
22 5102 00 10 05
25 1689 50 00 45
24 0189 00 00 00

* For use with D5LC air heater only

Altitude kit *
Air pressure sensor for heating mode at altitudes up to 4,000 m above sea level

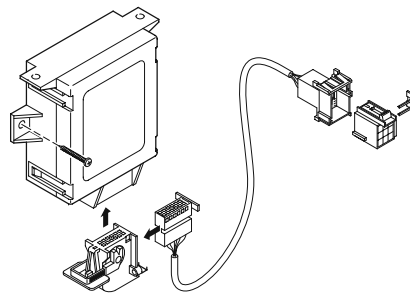

* For use with the Airtronic/Airtronic M and Hydronic/Hydronic 2 labeled "H-Kit" on the factory plate on the side

22 1000 33 22 00

Adapter cable
For air pressure sensor diagnostics

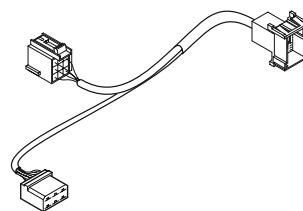

22 1000 33 31 00

Diagnostic device

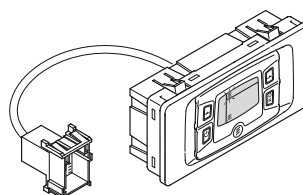

22 1545 89 00 00

- 1
- 2
- 3
- 4
- 5
- 6
- 7
- 8
- 9
- 10
- 11
- 12
- 13

9 | TESTING EQUIPMENT

EDiTH Basic *

Incl. USB-to-serial adapter and software CD for the EDiTH diagnostics tool for testing installed heater systems

Functions:

- Reads errors from the control unit
- Runs diagnostics on the installed heater
- Switches on the heater direct from the PC
- Displays functional sequence
- Displays operational state and measured values
- Detects altitude capability of heater
- Displays heater data
- Help function
- IPCU programming capability
- Software available in several languages

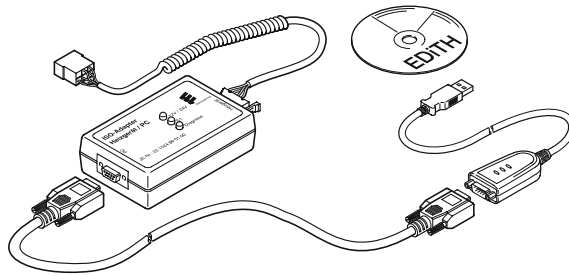

* Change of product designation, now ISO adapter

EDiTH Basic for Toyota Avensis

See above for illustration/product package

		Airtronic	Airtronic M	Airtronic L	Air heater 8 L / V 7 S	Hydronic 4 / 5 KW	Hydronic M / M2	Hydronic L / L2	Order no.
									22 1541 89 00 00
									22 1526 89 00 00
1	Adapter cable *								
	For diagnostic device and EDiTH Basic								
									22 1000 31 86 00
									22 1000 31 63 00
2									22 1000 33 78 00
									22 1000 32 52 00
									22 1000 33 44 00
3	* Cable harness with diagnostic connector								22 1000 31 66 00
									22 1000 34 11 02
4	Adapter cable for older models of heater								
	For diagnostic device and EDiTH Basic								
5									22 1000 30 69 00
									22 1000 30 20 00
6									22 1000 31 83 00
7	Adapter cable								
	Vehicle-specific, for diagnostic device and EDiTH Basic								
									22 1526 89 03 00
8									22 1000 31 16 00
9	Adapter cable for older models of heater								
	Vehicle-specific, for diagnostic device and EDiTH Basic								
10									
11									
12									22 1000 32 20 00
									22 1000 30 32 00
									22 1000 31 25 00
									22 1000 31 23 00
13									22 1000 31 21 00

9 | TESTING EQUIPMENT

EDiTH Expert *

Incl. USB-to-serial adapter and software CD for the EDiTH diagnostic tool

Functions:

- Reads errors from the control unit
- Runs diagnostics on the dismantled control unit
- Control unit function testing under real load conditions
- Full testing for installed Hydronic 4/5 heaters without Eberspächer diagnostics or hardware activation of diagnostics
- Detects altitude capability of control unit
- Displays heater data
- Help function
- IPCU programming capability
- Software available in several languages

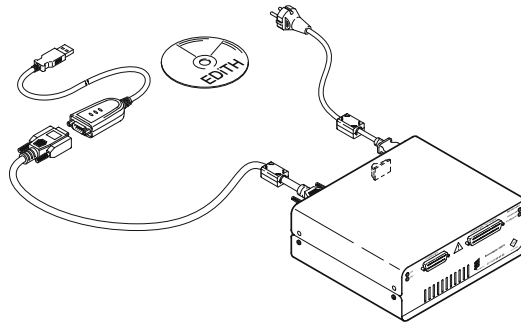

* Change of product name, now EDITH basic test adapter

USB-to-serial adapter

Incl. EDiTH diagnostic tool software CD

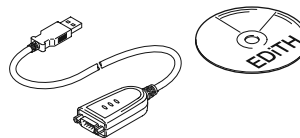

EDiTH Expert expansion for Hydronic 3/4/5 control unit

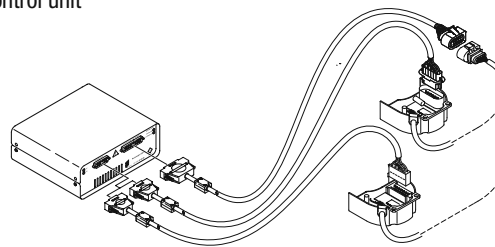

EDiTH Expert expansion for Hydronic 2 control unit

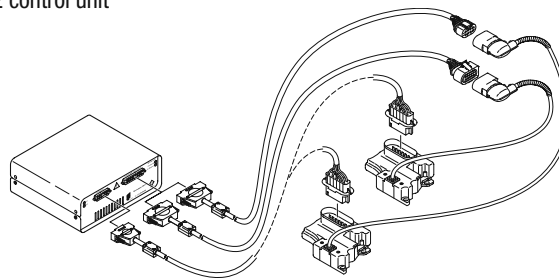

EDiTH Expert expansion for D2 I control unit

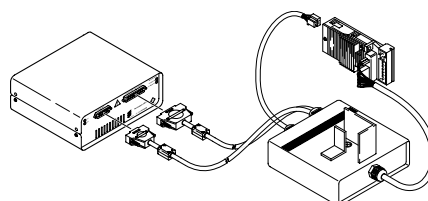

B/D1 LC compact, B/D3 LC compact

Airtronic	Airtronic M	Airtronic L	Air heater 8 L / V 7 S	Hydronic 4 / 5 KW	Hydronic M / M2	Hydronic L / L2	Order no.
							22 1542 89 00 00
							22 1543 89 00 00
							22 1533 89 00 00
							22 1534 89 00 00
							22 1535 89 00 00

- 1
- 2
- 3
- 4
- 5
- 6
- 7
- 8
- 9
- 10
- 11
- 12
- 13

9 | TESTING EQUIPMENT

EDiTH Expert expansion for D 2 H control unit

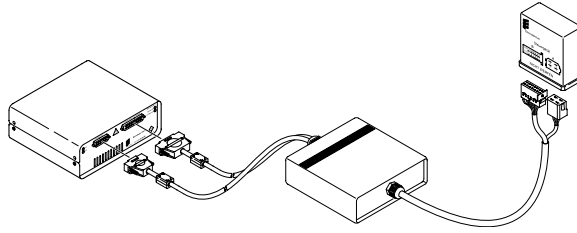

B/D1 LC, B/D3 LC

22 1536 89 00 00

EDiTH Expert expansion for Airtronic control unit

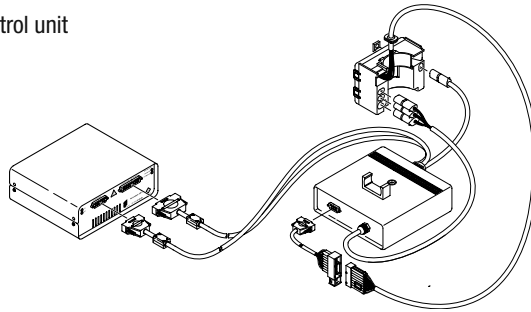

22 1537 89 00 00

EDiTH Expert expansion for Hydronic M control unit

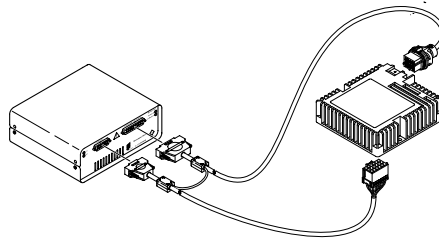

with Hydronic M only

22 1538 89 00 00

EDiTH Expert expansion for Hydronic L control unit

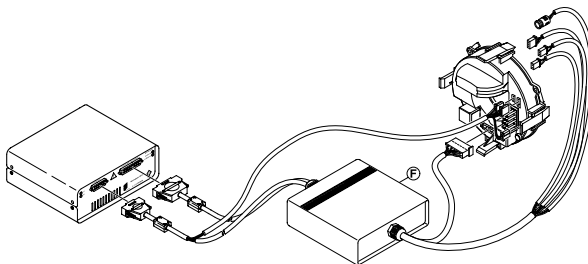

22 1539 89 00 00

Airtronic	Airtronic M	Airtronic L	Air heater 8 L / V 7 S	Hydronic 4 / 5 KW	Hydronic M / M2	Hydronic L / L2	Order no.
							22 1536 89 00 00
							22 1537 89 00 00
							22 1538 89 00 00
							22 1539 89 00 00

- 1
- 2
- 3
- 4
- 5
- 6
- 7
- 8
- 9
- 10
- 11
- 12
- 13

9 | TESTING EQUIPMENT

EDiTH Expert expansion for complete test

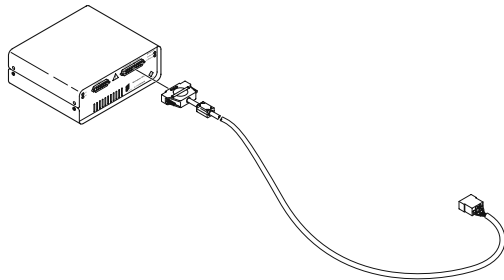

Airtronic	Airtronic M	Airtronic L	Air heater 8 L / V 7 S	Hydronic 4 / 5 KW	Hydronic M / M2	Hydronic L / L2	Order no.
-----------	-------------	-------------	------------------------	-------------------	-----------------	-----------------	-----------

22 1540 89 00 00

VW T4 adapter cable

For diagnostic device 22 1512 89 00 00 only

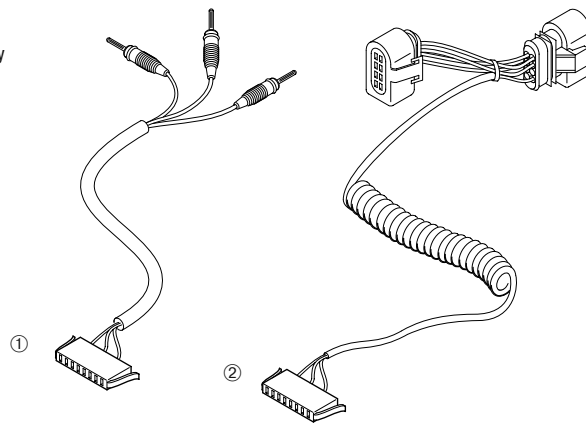

①
②

22 1520 89 02 00
22 1520 89 01 00

Test adapter

With test software for D 2 H control units
Operating systems supported: DOS, WIN 3.11/95/98

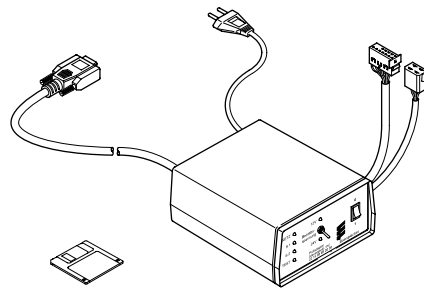

B/D1 LC, B/D3 LC, B/D3 LP

22 1508 89 00 00

Adapter cable

With test software for test adapter
Operating systems supported: DOS, WIN 3.11/95/98

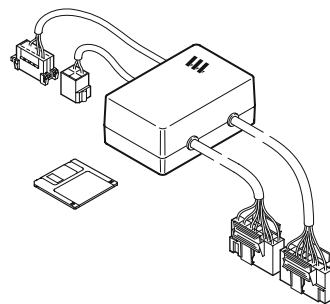

B/D5 W, D 24 W, D 30 W

22 1517 89 00 00

1

2

3

4

5

6

7

8

9

10

11

12

13

10 | EXHAUST AND COMBUSTION-AIR SYSTEM

GENERAL INFORMATION:

The exhaust and combustion-air system must be installed in such a way that it ensures the following:

- The connection to the heater plug is sealed.
- The mouth of the pipe is never facing a head wind.
- As far as possible, the mouth of the pipe is protected from spray water ingress and spray must be able to run straight out again without penetrating the heater.
- There is no possibility of heater or vehicle engine exhaust gases being sucked in.
- Please also refer to the safety information on this section in the heater documentation.

Installing the exhaust line:

- Exhaust pipes should always be installed with a fall towards the tail of the pipe.
- If this is not possible, a water drainage hole must be drilled at the lowest point.
- 1 ▪ If this point is not in the open air (e.g. in a ship's engine room), this opening must have a sealed connection to an overflow vessel.
- 2 ▪ Under no circumstances must any cross-sections in the exhaust line be narrower than those on the heater exhaust connection.
- 3 ▪ For permissible lengths, diameters and curvatures in the combustion-air and exhaust lines, see the technical information and installation instructions.
- 4
- 5
- 6
- 7
- 8
- 9
- 10
- 11
- 12
- 13

10 | EXHAUST AND COMBUSTION-AIR SYSTEM

Exhaust hose
2-layer stainless steel (Meterware)

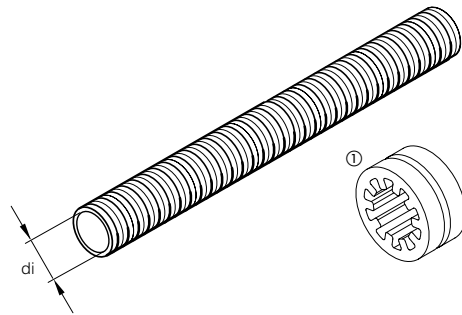

①
See page 121 for spacer ring

~ = In combination with exhaust pipe elbow 25 1226 89 46 00

3,000 mm long, di = 24 mm
di = 30 mm
di = 40 mm
di = 42 mm

Airtronic	Airtronic M	Airtronic L	Air heater 8 L / V 7 S	Hydronic 4 / 5 KW	Hydronic M / M2	Hydronic L / L2	Order no.
■	■	■					360 61 299
			~		■		360 61 300
							360 61 380
			■				360 61 381

Airtronic	Airtronic M	Airtronic L	Air heater 8 L / V 7 S	Hydronic 4 / 5 KW	Hydronic M / M2	Hydronic L / L2	Order no.
■	■	■					25 1774 89 10 00
■	■	■					25 1774 89 12 00
■	■	■					25 1774 89 14 00
					■		25 1816 80 08 00

Airtronic	Airtronic M	Airtronic L	Air heater 8 L / V 7 S	Hydronic 4 / 5 KW	Hydronic M / M2	Hydronic L / L2	Order no.
■	■	■					360 00 363
■	■	■					25 1676 80 00 01
■	■	■					24 0151 00 00 05
					■		25 1894 80 04 01
						~	25 1445 05 03 04

Exhaust hose with end sleeve
1-layer stainless steel

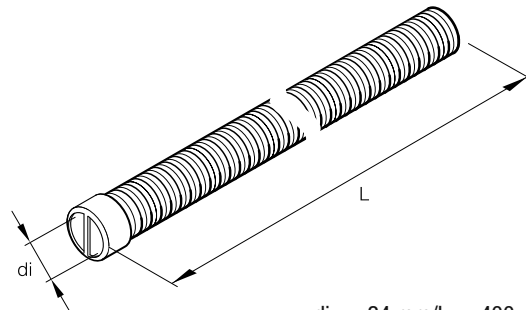

di = 24 mm/L = 400 mm
di = 24 mm/L = 500 mm
di = 24 mm/L = 800 mm
di = 30 mm/L = 1,300 mm

Fiberglass hose
Heat protection

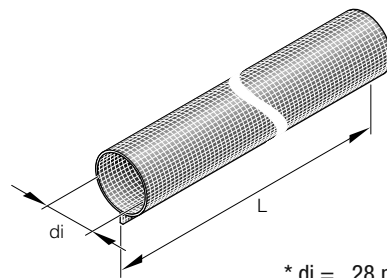

* Silicone coated

~ = Check diameter of exhaust line

* di = 28 mm, L = 500 mm
di = 30 mm, L = 300 mm
di = 30 mm, L = 150 mm
di = 40 mm, L = 60 mm
di = 70 mm, L = 1,200 mm

- 1
- 2
- 3
- 4
- 5
- 6
- 7
- 8
- 9
- 10
- 11
- 12
- 13

10 | EXHAUST AND COMBUSTION-AIR SYSTEM

End sleeve with crossbar for exhaust pipe



∅ 24 mm

Airtronic	Airtronic M	Airtronic L	Air heater 8 L / V 7 S	Hydronic 4 / 5 KW	Hydronic M / M2	Hydronic L / L2	Order no.
■	■	■	■	■			25 1729 80 06 00

End sleeve for exhaust pipe

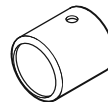

∅ 30 mm
∅ 42 mm

			■		■		25 1785 80 02 00
			■				22 1000 40 02 00

Transition piece for exhaust hose

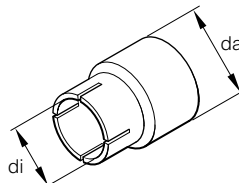

di = 24 mm, da = 30 mm

■	■	■	■				25 1520 80 01 01
---	---	---	---	--	--	--	------------------

Adapter with condensate drainage

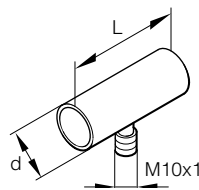

d = 24 mm, L = 65 mm
d = 30 mm, L = 60 mm

■	■	■	■				22 1050 89 40 00
					■		25 1226 89 59 00

Exhaust pipe angle

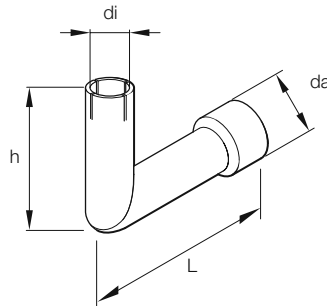

di = 24 mm, da = 30 mm, h = 50 mm/80 mm

■	■	■	■				25 1226 89 55 00
---	---	---	---	--	--	--	------------------

10 | EXHAUST AND COMBUSTION-AIR SYSTEM

M10 x 1 exhaust pipe elbow with drainage

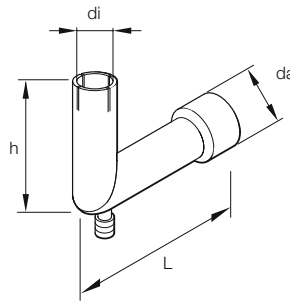

di = 24 mm, da = 24 mm, h = 50 mm, L = 110 mm
 di = 24 mm, da = 30 mm, h = 50 mm, L = 80 mm

Airtronic	Airtronic M	Airtronic L	Air heater 8 L / V 7 S	Hydronic 4 / 5 KW	Hydronic M / M2	Hydronic L / L2	Order no.
-----------	-------------	-------------	------------------------	-------------------	-----------------	-----------------	-----------

■	■	■	■	■	■	■	25 1226 89 45 00
■	■	■	■	■	■	■	22 1050 89 39 00

Condensate drain

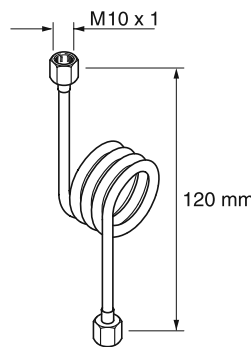

~ = Only for use with parts that have condensate drainage

~	~	~	~	~	~	~	25 8547 16 02 00
---	---	---	---	---	---	---	------------------

Exhaust pipe elbow

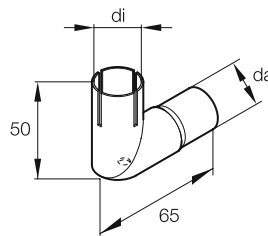

with condensate hole, di = 24 mm, da = 24 mm
 without condensate hole, di = 24 mm, da = 24 mm

■	■	■	■	■	■	■	24 0076 07 01 00
■	■	■	■	■	■	■	24 0172 01 01 00

Exhaust pipe elbow

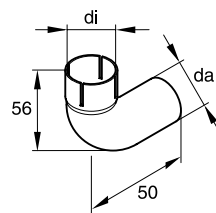

di = 24 mm, da = 24 mm

■	■	■	■	■	■	■	25 2481 80 02 02
---	---	---	---	---	---	---	------------------

M10 x 1 exhaust pipe elbow with drainage

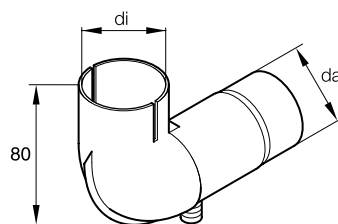

di = 42 mm, da = 40 mm

■	■	■	■	■	■	■	25 1226 89 46 00
---	---	---	---	---	---	---	------------------

- 1
- 2
- 3
- 4
- 5
- 6
- 7
- 8
- 9
- 10
- 11
- 12
- 13

10 | EXHAUST AND COMBUSTION-AIR SYSTEM

Exhaust pipe elbow

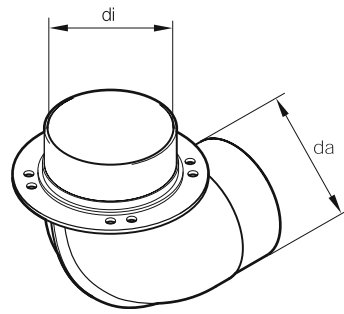

di = 70 mm, da = 72 mm

Airtronic	Airtronic M	Airtronic L	Air heater 8 L / V 7 S	Hydronic 4 / 5 KW	Hydronic M / M2	Hydronic L / L2	Order no.
-----------	-------------	-------------	------------------------	-------------------	-----------------	-----------------	-----------

22 1000 40 03 00

Exhaust connection

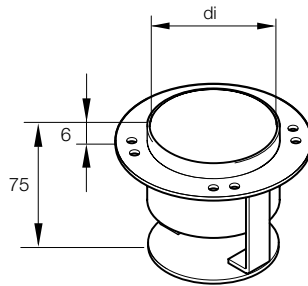

di = 70 mm

Airtronic	Airtronic M	Airtronic L	Air heater 8 L / V 7 S	Hydronic 4 / 5 KW	Hydronic M / M2	Hydronic L / L2	Order no.
-----------	-------------	-------------	------------------------	-------------------	-----------------	-----------------	-----------

22 1000 40 04 00

Exhaust muffler

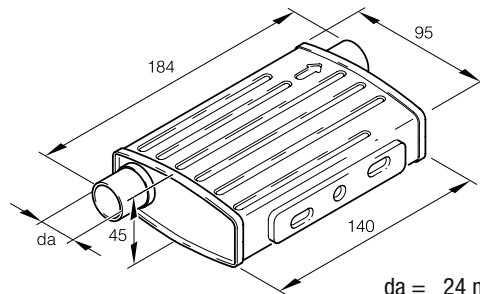

The exhaust muffler must not be installed in boat interiors.

See page 124 for exhaust muffler mounting bracket

da = 24 mm

Airtronic	Airtronic M	Airtronic L	Air heater 8 L / V 7 S	Hydronic 4 / 5 KW	Hydronic M / M2	Hydronic L / L2	Order no.
-----------	-------------	-------------	------------------------	-------------------	-----------------	-----------------	-----------

22 1000 40 19 00

Exhaust muffler

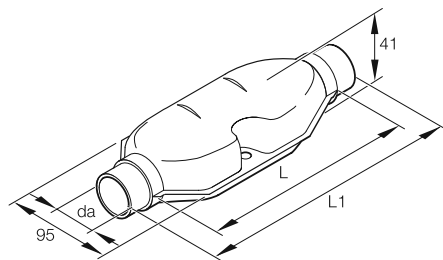

The exhaust muffler must not be installed in boat interiors.

da = 30 mm, L = 180 mm, L1 = 224 mm

Airtronic	Airtronic M	Airtronic L	Air heater 8 L / V 7 S	Hydronic 4 / 5 KW	Hydronic M / M2	Hydronic L / L2	Order no.
-----------	-------------	-------------	------------------------	-------------------	-----------------	-----------------	-----------

25 1806 80 01 00

Exhaust muffler

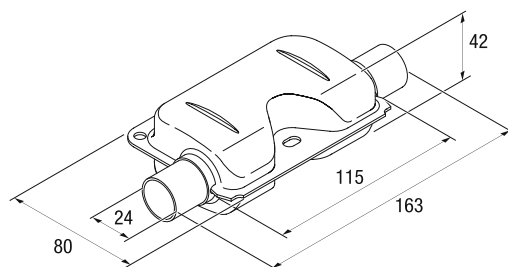

The exhaust muffler must not be installed in boat interiors.

da = 24 mm

Airtronic	Airtronic M	Airtronic L	Air heater 8 L / V 7 S	Hydronic 4 / 5 KW	Hydronic M / M2	Hydronic L / L2	Order no.
-----------	-------------	-------------	------------------------	-------------------	-----------------	-----------------	-----------

25 1864 81 01 00

- 1
- 2
- 3
- 4
- 5
- 6
- 7
- 8
- 9
- 1
- 1
- 1
- 1

10 | EXHAUST AND COMBUSTION-AIR SYSTEM

Exhaust muffler
Flexible stainless steel, for boats

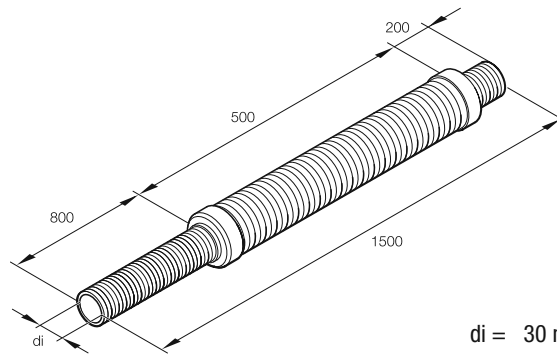

~ = Check connection diameter

$d_i = 30 \text{ mm}$

Oxidation catalyst

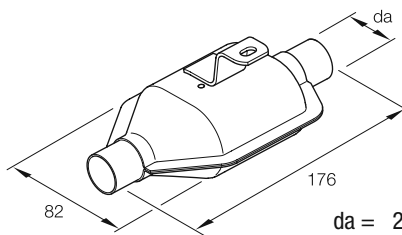

Only for diesel heaters; not suitable for use with PME (biodiesel).

$d_a = 24 \text{ mm}$

Hull fitting
Polished stainless steel

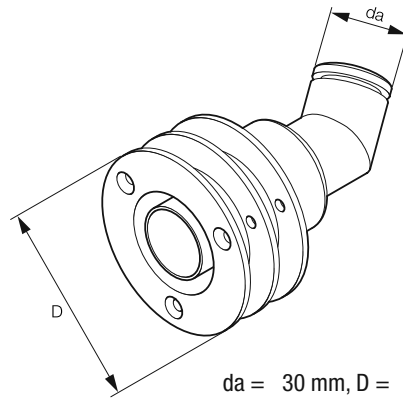

$d_a = 30 \text{ mm}, D = 90 \text{ mm}$

Self-adhesive aluminum film
Heat protection film

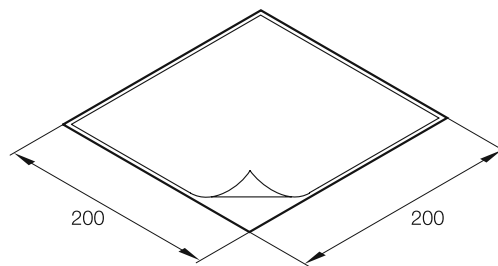

Airtronic	Airtronic M	Airtronic L	Air heater 8 L / V 7 S	Hydronic 4 / 5 KW	Hydronic M / M2	Hydronic L / L2	Order no.
~	~	~	~	■			25 1226 89 58 00
				■	■		22 1000 40 17 00
~	~	~	~	■			22 1050 89 43 00
				■	■	■	871 00 051

- 1
- 2
- 3
- 4
- 5
- 6
- 7
- 8
- 9
- 10**
- 11
- 12
- 13

10 | EXHAUST AND COMBUSTION-AIR SYSTEM

Flexible pipe for combustion air (linear m)

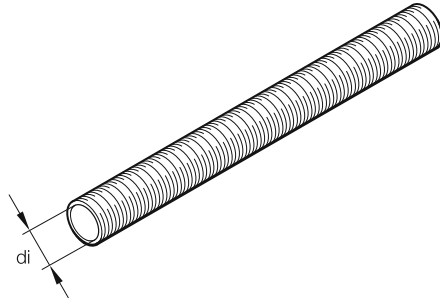

di = 20 mm
di = 25 mm

Airtronic	Airtronic M	Airtronic L	Air heater 8 L / V 7 S	Hydronic 4 / 5 KW	Hydronic M / M2	Hydronic L / L2	Order no.
-----------	-------------	-------------	------------------------	-------------------	-----------------	-----------------	-----------

360 00 092
10 2114 21 00 00

Flexible double pipe for combustion air
Sound-absorbing

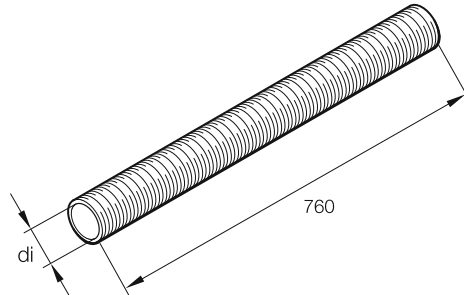

di = 20 mm

360 00 179

1 End sleeve with crossbar for combustion-air pipe

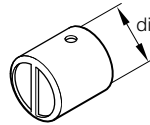

di = 20 mm
di = 25 mm

25 1688 80 12 01
25 1729 89 00 02

5 Air filter for combustion air

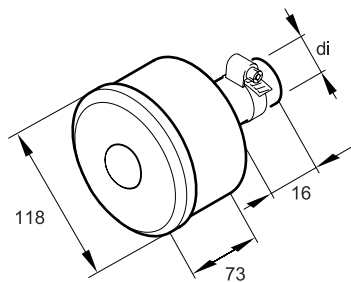

di = 25 mm

330 00 051

~ = Check connection diameter

10 Air filter insert
For air filter 330 00 051

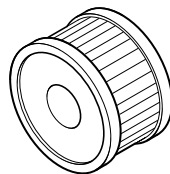

237 00 052

10 | EXHAUST AND COMBUSTION-AIR SYSTEM

Elbow for combustion air
Plastic

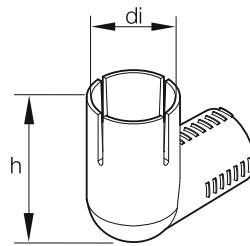

di = 20 mm, h = 45 mm
di = 25 mm, h = 50 mm

Airtronic	Airtronic M	Airtronic L	Air heater 8 L / V 7 S	Hydronic 4 / 5 KW	Hydronic M / M2	Hydronic L / L2	Order no.
				■			22 1000 40 00 02
■	■	■					22 1000 40 00 01

Scoop with hose connection

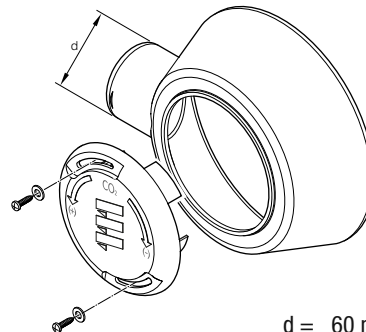

d = 60 mm

Flexible hose, see page 76

							22 1000 40 06 00
--	--	--	--	--	--	--	------------------

Muffler for combustion air
Flexible

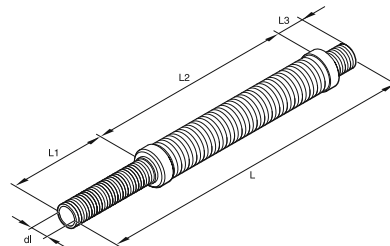

di = 20 mm, L1 = 100 mm, L2 = 160 mm, L3 = 100 mm, L = 360 mm
di = 25 mm, L1 = 135 mm, L2 = 405 mm, L3 = 25 mm, L = 565 mm
di = 25 mm, L1 = 100 mm, L2 = 555 mm, L3 = 30 mm, L = 685 mm

				■	■	■	22 1000 40 00 08
■	■	■			■		20 1689 80 05 00
■	■	■					25 1945 80 13 00

Muffler for combustion air
Flexible

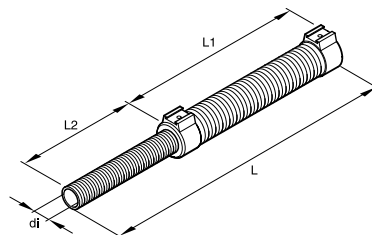

di = 20 mm, L1 = 160 mm, L2 = 130 mm, L = 290 mm

				■			22 1000 40 00 06
--	--	--	--	---	--	--	------------------

Boat wall opening for combustion air
Max. boat wall thickness 20 mm

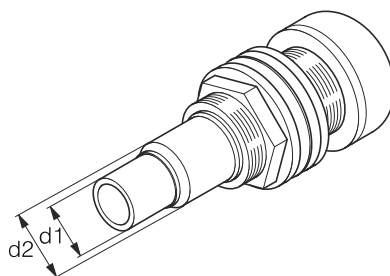

d1 = 25 mm, d2 = 30 mm

				■	■	■	22 1050 89 35 00
--	--	--	--	---	---	---	------------------

- 1
- 2
- 3
- 4
- 5
- 6
- 7
- 8
- 9
- 10
- 11
- 12
- 13

11 | FASTENING PARTS

GENERAL INFORMATION:

- The fastening parts supplied take account of all standard installation conditions.
- In installations in cars and buses, the heater or its mount can usually be rigidly attached to the corresponding part of the body.
- However in trucks and in particular, construction machinery, rubber-metal buffers need to be installed as vibration dampers, but these must not be placed under tension or shearing stress.
- This type of rubber-metal component also reduces structure-borne noise transmission and so they are used e.g. on houseboats for installing both the heater and the metering pump.
- Please also refer to the safety information on this section in the heater documentation.

1

2

3

4

5

6

7

8

9

10

11

12

13

11 | FASTENING PARTS

Hose clip

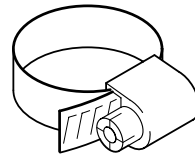

~ = Check connection diameter

	Airtronic	Airtronic M	Airtronic L	Air heater 8 L / V 7 S	Hydronic 4 / 5 KW	Hydronic M / M2	Hydronic L / L2	Order no.
∅ 16 – ∅ 25 mm					■			10 2067 01 60 25
∅ 20 – ∅ 32 mm	■	■	■		■	■		10 2067 02 00 32
∅ 32 – ∅ 50 mm				■			■	10 2067 03 20 50
∅ 40 – ∅ 47 mm				~				15 2090 17
∅ 50 – ∅ 70 mm	■							10 2067 05 00 70
∅ 70 – ∅ 90 mm	■	~	~					10 2067 07 00 90
∅ 90 – ∅ 110 mm		■	■	■				10 2067 09 01 10

Hose clip with lug



~ = Check connection diameter

∅ 9 – ∅ 10.5 mm	■	■	■	■	■	■	■	152 61 104
∅ 21 – ∅ 24.0 mm					■	~		152 61 115

Hose clip



~ = Check connection diameter

∅ 7 mm	~	~	~	~	~	~		10 2068 00 70 78
∅ 9 mm	■	■	■	■	■	■		10 2068 00 90 98
∅ 10 mm	■	■	■	■	■	■		10 2068 01 00 98
∅ 11 mm	■	■	■	■	■	■		10 2068 01 10 98
∅ 12 mm	■	■	■	■	■	■		10 2068 01 20 98
∅ 14 mm	~	~	~	~	~	~	~	10 2068 01 40 98

Pipe clip for exhaust pipe

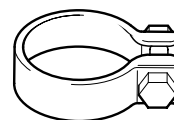

∅ 26–∅ 28 mm	■	■	■	■				22 1000 50 05 00
--------------	---	---	---	---	--	--	--	------------------

Pipe clip for exhaust pipe

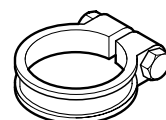

∅ 27 – ∅ 30 mm						■		152 09 002
∅ 30 – ∅ 33 mm						■		152 09 003
∅ 42 – ∅ 45 mm				■				152 09 004
∅ 43 – ∅ 46 mm				■				152 09 005

11 | FASTENING PARTS

Mounting bracket for metering pump
and Flowtronic 800 S water pump (page 68)
Rubber

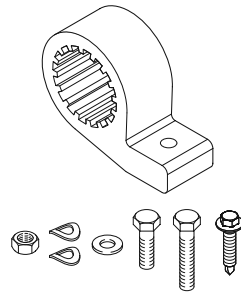

Fuel, \varnothing 34 mm
Water, \varnothing 41 mm

Airtronic	Airtronic M	Airtronic L	Air heater 8 L / V 7 S	Hydronic 4 / 5 KW	Hydronic M / M2	Hydronic L / L2	Order no.
-----------	-------------	-------------	------------------------	-------------------	-----------------	-----------------	-----------

							22 1000 50 03 00
							22 1000 50 07 00

Air hose fastening kit
Plastic, 3 per pack

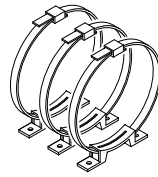

\varnothing 60 – \varnothing 100 mm

							22 1000 50 02 00
--	--	--	--	--	--	--	------------------

Clip
Galvanized

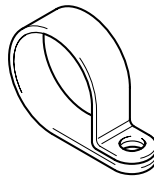

\varnothing 28 mm
 \varnothing 41 mm
 \varnothing 50 mm
 \varnothing 65 mm

							152 09 010
							152 10 039
							152 09 011
							152 09 012

Do not use for flexible exhaust pipes!

Clip
Stainless steel

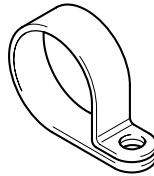

\varnothing 25 mm
 \varnothing 28 mm
 \varnothing 32 mm

							152 10 048
							152 61 001
							152 10 069

Pipe clip with rubber inlay

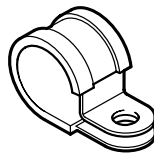

\varnothing 10 mm
 \varnothing 41 mm

							152 00 139
							152 00 131

Fastening clip
For water hoses, \varnothing 15 mm– 20 mm

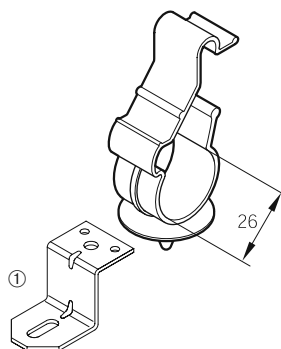

① See page 124 for mounting bracket

							156 31 011
--	--	--	--	--	--	--	------------

11 | FASTENING PARTS

Mounting bracket for metering pump
For use with boats and camping vehicles

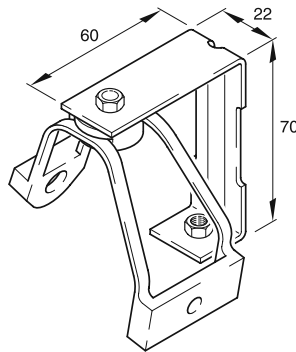

Airtronic	Airtronic M	Airtronic L	Air heater 8 L / V 7 S	Hydronic 4 / 5 KW	Hydronic M / M2	Hydronic L / L2	Order no.
							20 1634 80 06 00

Rubber spacer profile for exhaust line and water hoses
Silicone rubber, temperature resistant

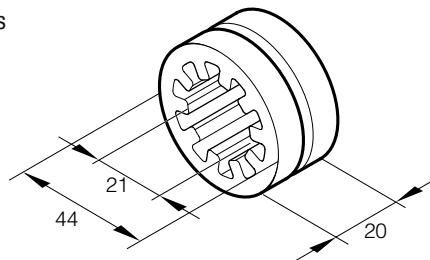

							22 1000 50 10 02
--	--	--	--	--	--	--	------------------

Gasket for exhaust pipe

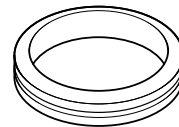

di = 41 mm

							20 8542 11 00 02
--	--	--	--	--	--	--	------------------

Mounting bracket for water pump
For use with water pump 25 2217 27 00 00
(see page 68)

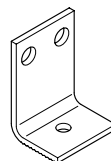

							25 2217 27 01 00
--	--	--	--	--	--	--	------------------

- 1
- 2
- 3
- 4
- 5
- 6
- 7
- 8
- 9
- 10
- 11
- 12
- 13

11 | FASTENING PARTS

Gasket for heating-air line

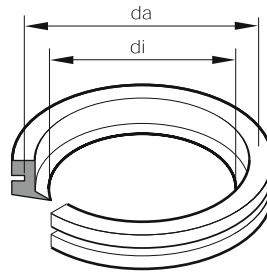

di = 72–85 mm, da = 100 mm

Rubber grommet

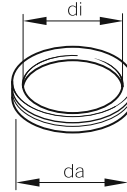

di = 4–10 mm, da = 16.5 mm

Grommet for combustion-air pipe

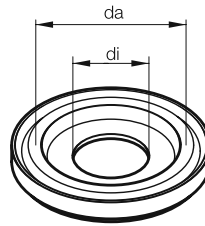

di = 25–30 mm, da = 41 mm

Grommet for exhaust pipe

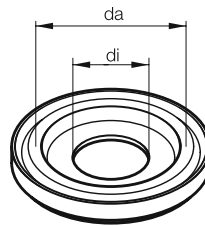

di = 23–30 mm, da = 41 mm
di = 38–45 mm, da = 60 mm

Airtronic	Airtronic M	Airtronic L	Air heater 8 L / V 7 S	Hydronic 4 / 5 KW	Hydronic M / M2	Hydronic L / L2	Order no.
■	■	■					20 1280 04 00 01
■	■	■	■	■	■	■	20 1280 09 01 03
■	■	■	■	■	■	■	20 1282 20 00 01
■	■	■	■	■	■	■	20 1549 65 00 02 20 1282 20 00 02

- 1
- 2
- 3
- 4
- 5
- 6
- 7
- 8
- 9
- 10
- 11**
- 12
- 13

11 | FASTENING PARTS

Rubber-metal buffer

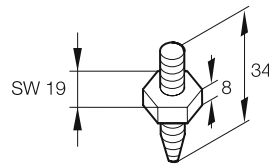

Airtronic	Airtronic M	Airtronic L	Air heater 8 L / V 7 S	Hydronic 4 / 5 KW	Hydronic M / M2	Hydronic L / L2	Order no.
-----------	-------------	-------------	------------------------	-------------------	-----------------	-----------------	-----------

thread size M6/ST 6.3 C x 15

20 1673 80 01 01

Rubber-metal buffer

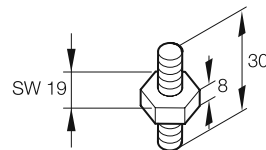

thread size 2 x M6 x 11 mm

20 1185 00 00 01

Rubber-metal buffer
Metal-reinforced

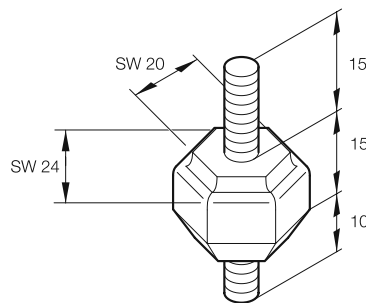

thread size M6 x 10 mm/M6 x 15 mm

22 1000 50 00 08

Rubber-metal buffer

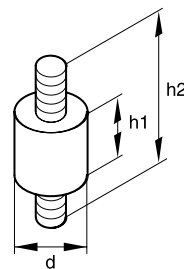

- thread size 2 x M6 x 10, d = 20 mm, h1 = 15 mm, h2 = 35 mm
- thread size 2 x M6 x 10, d = 20 mm, h1 = 25 mm, h2 = 45 mm
- thread size 2 x M8 x 13, d = 30 mm, h1 = 15 mm, h2 = 41 mm

- 20 1607 65 00 02
- 20 1609 05 00 04
- 330 09 002

- 1
- 2
- 3
- 4
- 5
- 6
- 7
- 8
- 9
- 10
- 11
- 12
- 13

11 | FASTENING PARTS

Mounting bracket

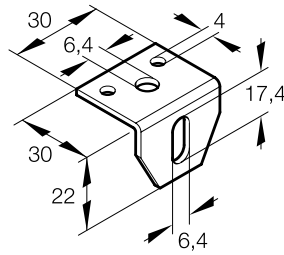

Airtronic	Airtronic M	Airtronic L	Air heater 8 L / V / 7 S	Hydronic 4 / 5 KW	Hydronic M / M2	Hydronic L / L2	Order no.
							20 1348 03 00 02

Mounting bracket

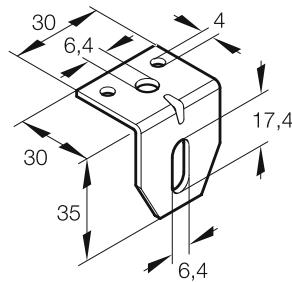

							20 1348 03 00 04
--	--	--	--	--	--	--	------------------

Mounting bracket

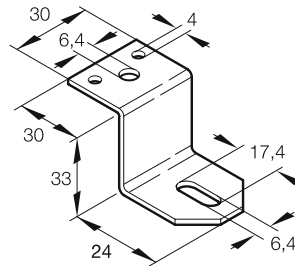

							20 1533 88 00 07
--	--	--	--	--	--	--	------------------

L-mounting bracket
For exhaust muffler 22 1000 40 19 00

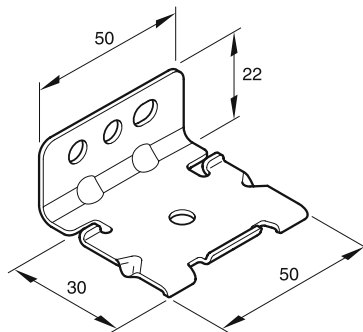

See page 114 for exhaust muffler

							22 1000 51 34 00
--	--	--	--	--	--	--	------------------

Z-mounting bracket
For exhaust muffler 22 1000 40 19 00

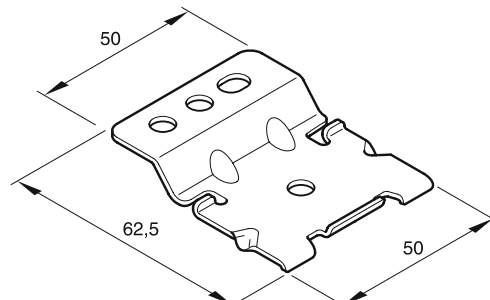

See page 114 for exhaust muffler

							22 1000 51 35 00
--	--	--	--	--	--	--	------------------

- 1
- 2
- 3
- 4
- 5
- 6
- 7
- 8
- 9
- 10
- 11
- 12
- 13

11 | FASTENING PARTS

Mounting frame for EasyStart T

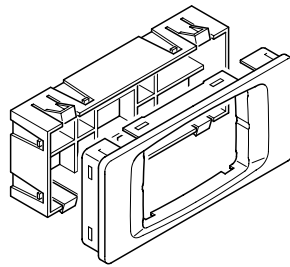

For use when replacing the modular timer with EasyStart T

Airtronic	Airtronic M	Airtronic L	Air heater 8 L / V 7 S	Hydronic 4 / 5 KW	Hydronic M / M2	Hydronic L / L2	Order no.
-----------	-------------	-------------	------------------------	-------------------	-----------------	-----------------	-----------

~	~	~	~	■	■	■	22 1000 51 33 00
---	---	---	---	---	---	---	------------------

EasyStart T – single part Fastening parts

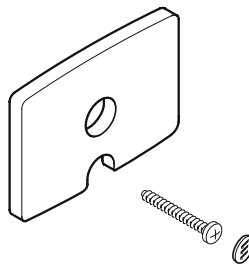

■	■	■	■	■	■	■	22 1000 32 93 00
---	---	---	---	---	---	---	------------------

EasyStart T – single part Bracket For slanting, level or convex installation surfaces

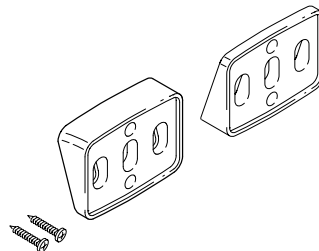

■	■	■	■	■	■	■	22 1000 51 32 00
---	---	---	---	---	---	---	------------------

Trim for EasyStart Timer

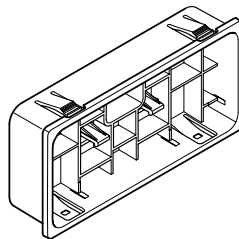

■	■	■	■	■	■	■	22 1000 51 41 00
---	---	---	---	---	---	---	------------------

Spacer plate Rubber

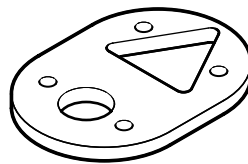

6 mm thick

■	■	■	■	■	■	■	25 1482 89 00 02
---	---	---	---	---	---	---	------------------

Unit mounting bracket

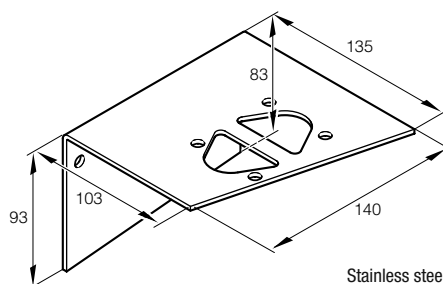

97°

Stainless steel, 105°

■	■	■	■	■	■	■	20 1575 89 00 10
■	■	■	■	■	■	■	22 1050 89 08 00

- 1
- 2
- 3
- 4
- 5
- 6
- 7
- 8
- 9
- 10
- 11
- 12
- 13

11 | FASTENING PARTS

Unit mounting bracket

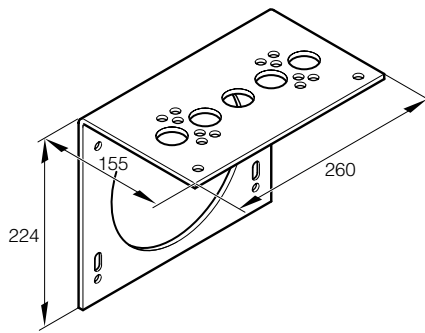

Airtronic	Airtronic M	Airtronic L	Air heater 8 L / V / 7 S	Hydronic 4 / 5 KW	Hydronic M / M2	Hydronic L / L2	Order no.
							24 0076 00 00 01

Heater mounting bracket

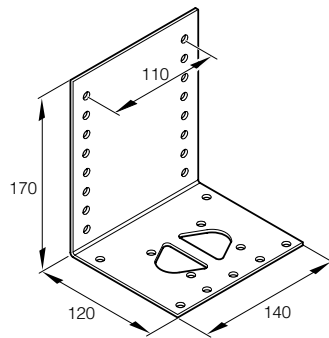

							25 1482 89 00 11
--	--	--	--	--	--	--	------------------

Unit mounting bracket

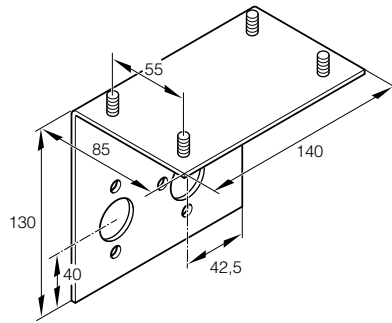

							20 1575 89 04 00
--	--	--	--	--	--	--	------------------

Mounting bracket
For vent, Item 10.1, page 77

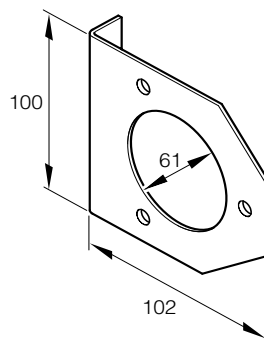

~ = Check connection diameter

			~	~			25 1688 89 00 09
--	--	--	---	---	--	--	------------------

Fastening plate

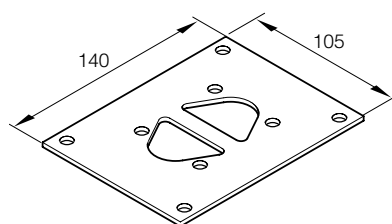

							25 1482 89 00 13
--	--	--	--	--	--	--	------------------

- 1
- 2
- 3
- 4
- 5
- 6
- 7
- 8
- 9
- 11
- 12
- 13

11 | FASTENING PARTS

Mounting bracket

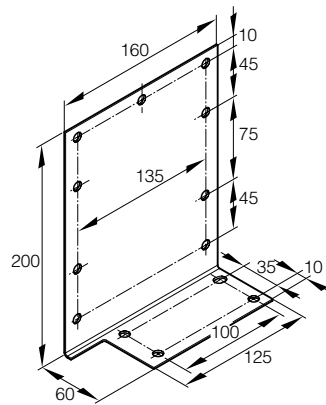

Airtronic	Airtronic M	Airtronic L	Air heater 8 L / V 7 S	Hydronic 4 / 5 KW	Hydronic M / M2	Hydronic L / L2	Order no.
-----------	-------------	-------------	------------------------	-------------------	-----------------	-----------------	-----------

22 1000 50 00 03

Mounting bracket

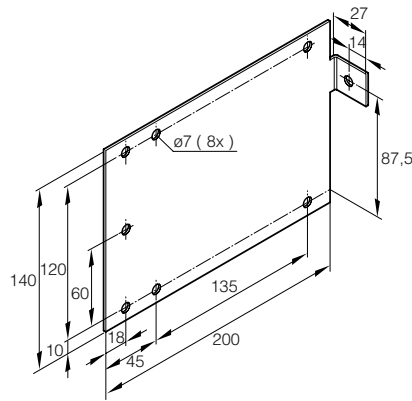

22 1000 50 00 06

Mounting bracket for Hydronic

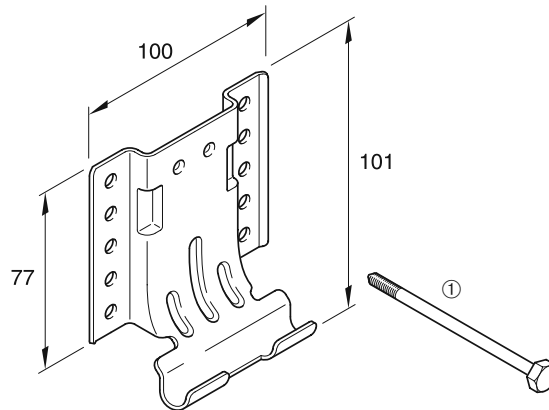

①
Also required:
M6x95 fastening screw, order no. 100 10 259

22 1000 51 36 00

Mounting bracket for Hydronic 2

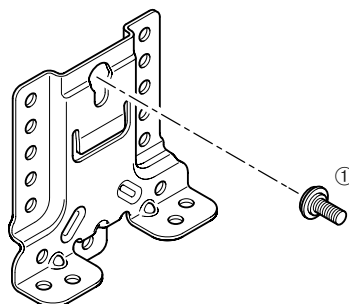

①
Special screw also required:
for Economy/Comfort 25 2526 80 01 01

22 1000 51 37 00

- 1
- 2
- 3
- 4
- 5
- 6
- 7
- 8
- 9
- 10
- 11
- 12
- 13

12 | NAME PLATES/INFORMATION SIGNS

GENERAL INFORMATION:

Name plates

The name plate must be easily visible after installation. If necessary, a second (duplicate) name plate can be attached in a clearly visible place on the heater after installation or on one of the covers in front of the heater. A second plate is not required if the original can be seen by removing a cover without the aid of tools.

A duplicate name plate is chargeable and can be sent on request. To order this, complete the form below and fax it to the number given.

The duplicate name plate costs EUR 15.

Please note!

Name plates for heaters with a general design certification (German: ABG – Allgemeine Bauartgenehmigung) are identifiable by the wavy line which is its mark of conformity (~~~~).



Name plates for heaters with an EC type approval are identifiable by the official EC and EMC  type approval mark.

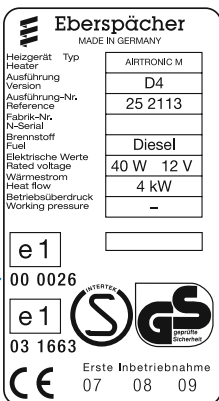

1

2

3

4

5

6

7

8

9

10

11

12

13

12 | NAME PLATES/INFORMATION SIGNS

ORDER SECOND NAME PLATE (DUPLICATE)

Copy this form, fill in the information from the original identification label and fax your order to:

+49 (0)711 939 1130

(Germany only)

Company	_____	
Contact	_____	
Street, building number	_____	
Zip code, town/city	_____	
Phone	_____	
Fax	_____	
Email	_____	
Sender (please print in block letters)	_____	1
<hr/>		
Heater type	_____	2
Version	_____	3
Version number	_____	4
Factory number	_____	5
Mark of conformity or EC type approval and EMC type approval	~~~~~ _____ e1 _____ e1 _____	6
Fuel	_____	7
Electrical values	_____	8
Heat flow	_____	9
Operating pressure	_____	10
		11
		12
		13

12 | NAME PLATES/INFORMATION SIGNS

Information sticker

**Vor dem Tanken
Heizgerät abstellen!**

**Before filling up
switch off heater!**

**Arrêter le chauffage
avant de remplir le réservoir!**

**Vid tankning
måste värmaren vara avstängd!**



Airtronic	Airtronic M	Airtronic L	Air heater 8 L / V / 7 S	Hydronic 4 / 5 KW	Hydronic M / M2	Hydronic L / L2	Order no.
-----------	-------------	-------------	--------------------------	-------------------	-----------------	-----------------	-----------

							20 1598 00 00 01
--	--	--	--	--	--	--	------------------

Information sticker

**Vor dem Betätigen des Batterie-
Trennschalters Heizgerät
abschalten und
Nachlauf abwarten.**

							25 1482 89 00 08
--	--	--	--	--	--	--	------------------

- 1
- 2
- 3
- 4
- 5
- 6
- 7
- 8
- 9
- 10
- 11
- 12
- 13

13 | AUXILIARY PRODUCTS – CONVECTORS

GENERAL INFORMATION ON THIRD-PARTY PRODUCTS:

Not all auxiliary products can be purchased direct from Eberspächer. Where applicable, these products must be ordered from the specified supplier.

Convectors and fan convectors with 2,000–10,000 W output.

HELIOS 2000

Incl. on/off switch, airflow/h 125 m³, 2 kW

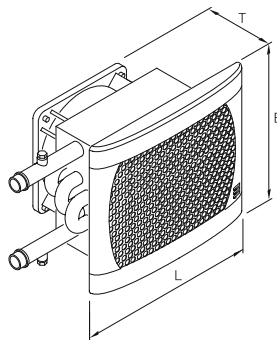

	Airtronic	Airtronic M	Airtronic L	Air heater 8 L/V 7 S	Hydronic	Hydronic M/Hydronic M-II	Hydronic L/Hydronic L-II	Order no.
Aluminum grille L = 172, B = 129, T = 107					~	~	~	22 2282 10 41 00
								24 V
Plastic grille, gray L = 200, B = 170, T = 105					~	~	~	22 2282 10 41 20
								24 V
Plastic grille, white L = 200, B = 170, T = 105					~	~	~	22 2282 10 41 21
								24 V
Plastic grille, black L = 200, B = 170, T = 105					~	~	~	22 2282 10 41 22
								24 V
Stainless steel grille L = 200, B = 170, T = 105					~	~	~	22 2282 10 41 09
								24 V

HELIOS 2000

Noiseless, incl. on/off switch, airflow/h 125 m³, 2 kW

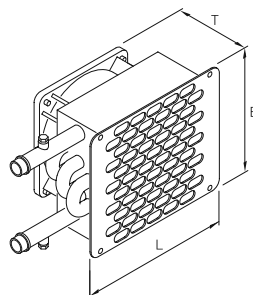

Aluminum grille L = 172, B = 129, T = 107					~	~	~	22 2282 10 41 26
								24 V
					~	~	~	22 2282 10 42 26

13 | AUXILIARY PRODUCTS – CONVECTORS

XEROS 4000
with fittings, airflow/h: 200 m³, 4 kW

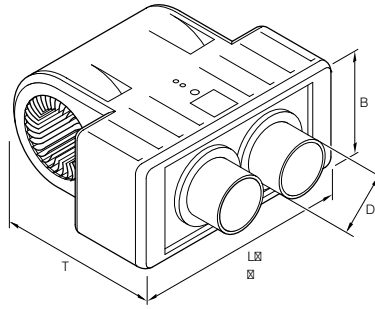

- with 2 fittings, \varnothing 45 12 V
L = 273, B = 114, T = 207 mm 24 V
- with 2 fittings, \varnothing 50 12 V
L = 273, B = 114, T = 207 mm 24 V
- with 2 fittings, \varnothing 60 12 V
L = 273, B = 114, T = 207 mm 24 V
- with 2 fittings, \varnothing 75 12 V
L = 273, B = 114, T = 207 mm 24 V
- with rotatable and closable vents 12 V
L = 273, B = 114, T = 207 mm

Airtronic	Airtronic M	Airtronic L	Air heater 8 L / V / S	Hydronic 4 / 5 KW	Hydronic M / M2	Hydronic L / L2	Order no.
				~	~	~	22 2282 11 01 66
				~	~	~	22 2282 11 02 66
				~	~	~	22 2282 11 01 61
				~	~	~	22 2282 11 02 61
				~	~	~	22 2282 11 01 63
				~	~	~	22 2282 11 02 63
				~	~	~	22 2282 11 01 65
				~	~	~	22 2282 11 02 65
				~	~	~	22 2282 11 01 53
<hr/>							
				~	~	~	22 2282 11 21 00
				~	~	~	22 2282 11 22 00
				~	~	~	22 2282 11 21 03
				~	~	~	22 2282 11 22 03
				~	~	~	22 2282 11 21 01
				~	~	~	22 2282 11 22 01
				~	~	~	22 2282 11 21 02
				~	~	~	22 2282 11 22 02
				~	~	~	22 2282 11 21 04
				~	~	~	22 2282 11 22 04
<hr/>							
				~	~	~	22 2282 11 31 00C
				~	~	~	22 2282 11 32 00C

ZENITH 8000
Airflow/h: 440 m³, 8 kW

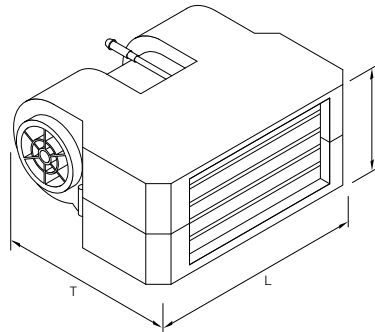

- Standard 12 V
L = 315, B = 130, T = 242 mm 24 V
- with plastic grilles 12 V
L = 315, B = 130, T = 242 mm 24 V
- with 3 fittings, \varnothing 60 12 V
L = 315, B = 130, T = 242 mm 24 V
- with 3 fittings, \varnothing 75 12 V
L = 315, B = 130, T = 242 mm 24 V
- with 4 fittings, \varnothing 60 12 V
L = 315, B = 130, T = 242 mm 24 V

ARTIK 10 000
Airflow/h: 440 m³, 10 kW

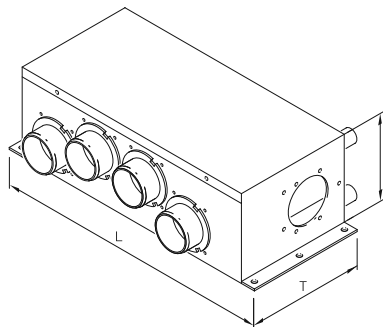

- Marine, stainless steel defroster 12 V
L = 442, B = 132, T = 225 24 V

- 1
- 2
- 3
- 4
- 5
- 6
- 7
- 8
- 9
- 10
- 11
- 12
- 13

13 | AUXILIARY PRODUCTS – CONVECTORS

Accessories

Grille for HELIOS 2000 convector

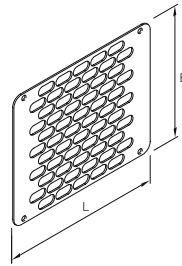

Aluminum
L = 170, B = 140

Stainless steel
L = 170, B = 140

Grille for HELIOS 2000 convector

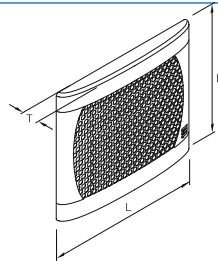

Plastic, black
L = 200, B = 170, T = 22

Plastic, white
L = 200, B = 170, T = 22

Plastic, gray
L = 200, B = 170, T = 22

Plastic grille for ZENITH 8000 convector

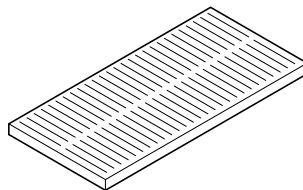

Plastic air diffuser with 3 fittings, for ZENITH 8000 convector

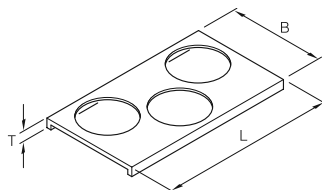

∅ 60 mm
L = 231, B = 131, T = 6

Airtronic	Airtronic M	Airtronic L	Air heater 8 L / V 7 S	Hydronic 4 / 5 KW	Hydronic M / M2	Hydronic L / L2	Order no.
			~	~	~		22 2134 08 60 00C
			~	~	~		22 2134 09 90 00B
			~	~	~		22 2134 10 10 01
			~	~	~		22 2134 10 10 02
			~	~	~		22 2134 10 10 00
			~	~	~		22 2145 73 50 00A
			~	~	~		22 2145 73 40 00A

- 1
- 2
- 3
- 4
- 5
- 6
- 7
- 8
- 9
- 10
- 11
- 12
- 13

13 | AUXILIARY PRODUCTS – CONVECTORS

Plastic air diffuser with 4 fittings, for ZENITH 8000 convector

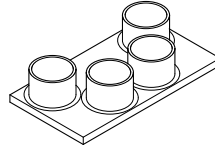

ø 60 mm

Fitting for air diffuser



ø 50 mm
ø 60 mm
ø 75 mm

Water hose

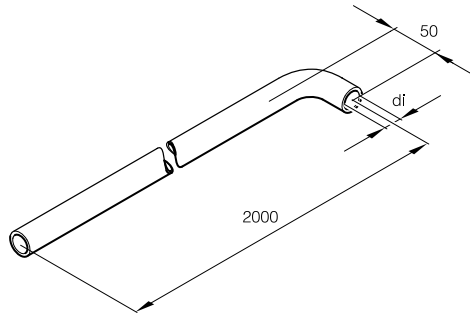

di = 18 mm

Pipe, aluminum

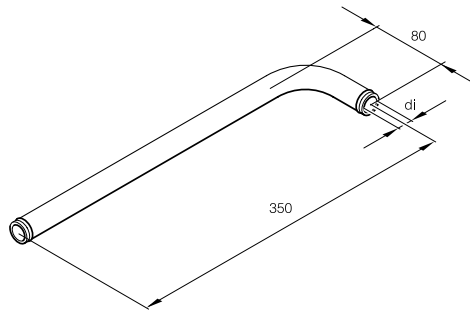

di = 18 mm

2-way motor control valve

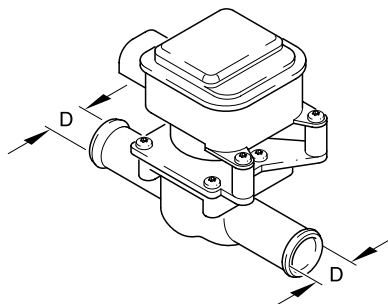

D = 22 mm

Airtronic	Airtronic M	Airtronic L	Air heater 8 L / V 7 S	Hydronic 4 / 5 KW	Hydronic M / M2	Hydronic L / L2	Order no.
			~	~	~		22 2145 73 70 00
			~	~	~		22 2000 06 57 07
			~	~	~		22 2000 06 58 87
			~	~	~		22 2000 06 57 27
			~	~	~		22 2330 04 20 00
			~	~	~		22 2175 00 00 91
			~	~	~		22 2118 02 60 00

- 1
- 2
- 3
- 4
- 5
- 6
- 7
- 8
- 9
- 10
- 11
- 12
- 13

13 | AUXILIARY PRODUCTS – INDIVIDUAL DEVICES

Warm water boiler

Supplier:

Eberspächer (UK) Ltd.
 Headlands Business Park
 Salisbury Road, Ringwood
 Hampshire BH24 3PB, UK
 Tel. +44 1425 480151
 Fax. +44 1425 480152

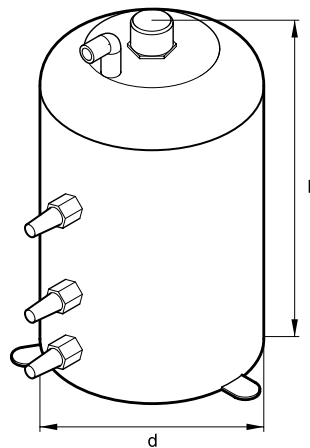

10 l, upright, single coil
 L = 390 mm, d = 250 mm

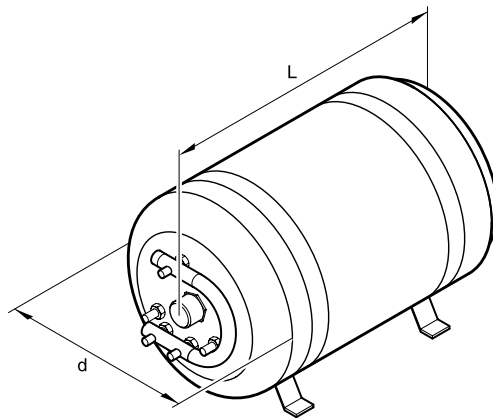

10 l, horizontal, single coil
 L = 550 mm, d = 250 mm

* 22 l, horizontal, single coil
 L = 510 mm, d = 370 mm

* 22 l, horizontal, double coil
 L = 510 mm, d = 370 mm

* 30 l, horizontal, single coil
 L = 610 mm, d = 370 mm

* 30 l, horizontal, double coil
 L = 610 mm, d = 370 mm

* 40 l, horizontal, single coil
 L = 750 mm, d = 370 mm

* 40 l, horizontal, double coil
 L = 750 mm, d = 370 mm

* 55 l, horizontal, single coil
 L = 970 mm, d = 370 mm

* 55 l, horizontal, double coil
 L = 970 mm, d = 370 mm

* 75 l, horizontal, single coil
 L = 1,130 mm, d = 400 mm

* 75 l, horizontal, double coil
 L = 1,130 mm, d = 400 mm

Airtronic	Airtronic M	Airtronic L	Air heater 8 L / V 7 S	Hydronic 4 / 5 KW	Hydronic M / M2	Hydronic L / L2	Order no.
				~	~	~	17700
				~	~	~	17722
				~	~	~	17794
				~	~	~	17795
				~	~	~	17796
				~	~	~	17797
				~	~	~	17798
				~	~	~	17799
				~	~	~	17800
				~	~	~	17801
				~	~	~	17802
				~	~	~	17803

* Thermostatic mixing valve

All warm water boilers have an integrated 220 V–240 V AC heating coil.

13 | AUXILIARY PRODUCTS – INDIVIDUAL DEVICES

Stainless steel box for Airtronic D2/D4

Supplier:

Kjöller Eberspächer Marine
 Rovsingsgade 82
 Copenhagen N, DK-2000, Denmark
 Tel. +45 35 82 95 00
 Fax. +45 35 82 50 95

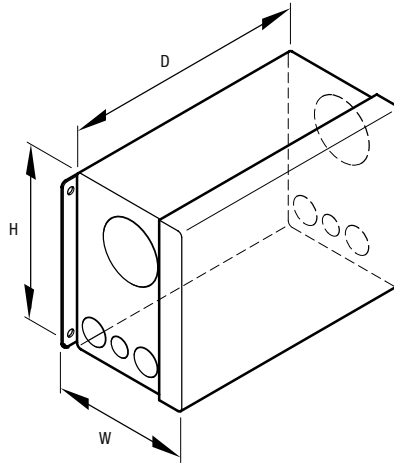

B = 147 mm, H = 212 mm, T = 295 mm
 B = 172 mm, H = 240 mm, T = 360 mm

Airtronic	Airtronic M	Airtronic L	Air heater 8 L / V 7 S	Hydronic 4 / 5 KW	Hydronic M / M2	Hydronic L / L2	Order no.
-----------	-------------	-------------	------------------------	-------------------	-----------------	-----------------	-----------

on request
 from manufacturer

Polarn 4000 Complete unit with Airtronic D4

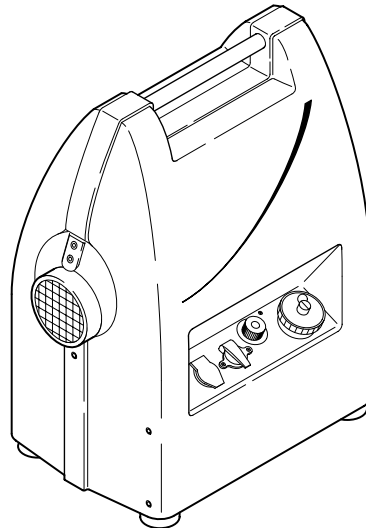

12 V/220 V
 12 V
 24 V

24 9988 00 00 21
 24 9988 00 00 10
 24 9988 00 00 22

POLARN 8000 Complete unit with air heater 8 L

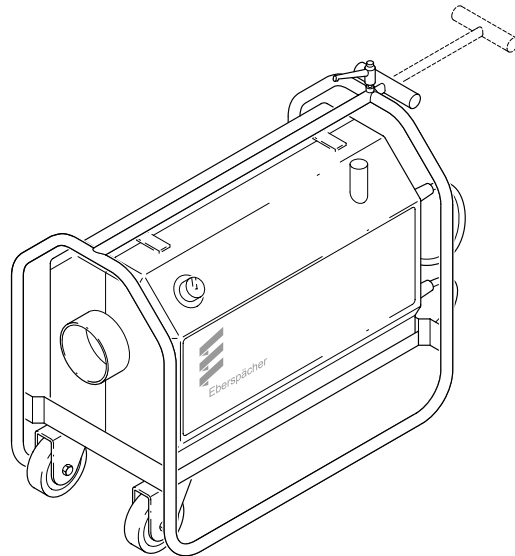

12 V
 24 V

24 9988 00 00 32
 24 9988 00 00 33

- 1
- 2
- 3
- 4
- 5
- 6
- 7
- 8
- 9
- 10
- 11
- 12
- 13

13 | AUXILIARY PRODUCTS – INDIVIDUAL DEVICES

Marine kit – air heater

Product package:

- Control element (mini-controller)
- Mounting bracket for heater
- Cable harness
- Combustion-air intake muffler
- Exhaust pipe angle
- Exhaust muffler
- Hull fitting
- Fuel tank extractor
- Fuel pipes
- Fuel hoses
- Temperature sensor
- Various mounting brackets
- Mounting accessories

To be ordered separately:
all air lines for the planned heating-air line

Optional:
EasyStart Timer timer switch (see page 92)

	Airtronic	Airtronic M	Airtronic L	Air heater 8 L / V 7 S	Hydronic 4 / 5 KW	Hydronic M / M2	Hydronic L / L2	Order no.
Airtronic D2 – 12 V Marine kit	■							24 8997 00 00 00
Airtronic D4 – 12 V Marine kit		■						24 8998 00 00 00
Airtronic D5 – 12 V Marine kit			■					24 8999 00 00 00

Marine kit – water heater

Hydronic D 5 WS – 12 V Marine kit				■				24 8992 00 00 00
Hydronic D 5 WS – 24 V Marine kit				■				24 8991 00 00 00
Hydronic M/M-II –12/24 V Marine kit						■		24 8993 00 00 00

Product package:

- Mounting bracket for heater
- Cable harness
- Combustion-air intake muffler
- Exhaust muffler
- Hull fitting
- Fuel tank extractor
- Fuel pipes
- Fuel hose
- Fastening parts
- Electrical parts
- Water hoses
- Connectors
- Mounting accessories

To be ordered separately:
EasyStart Timer timer switch (see page 92)

- 1
- 2
- 3
- 4
- 5
- 6
- 7
- 8
- 9
- 10
- 11
- 12
- 13

MORE INFORMATION IS AVAILABLE FROM ANY OF OUR 5,000 SERVICE PARTNERS
WORLDWIDE.

GERMANY

Eberspächer Heizung
Vertriebs-GmbH & Co. KG
Wilhelmstrasse 47
17358 Torgelow
Hotline: 01805 262626
Fax hotline: 01805 262624
vk-heiz@eberspaecher.com
www.eberspaecher.com

AUSTRIA

Eberspächer GmbH
IZ NÖ-Süd2
Hondastraße 2, Obj. M47
2351 Wiener Neudorf
Phone: +43 (0)2236 6771440
Fax: +43 (0)2236 67714442
office-at@eberspaecher.com
www.eberspaecher.at

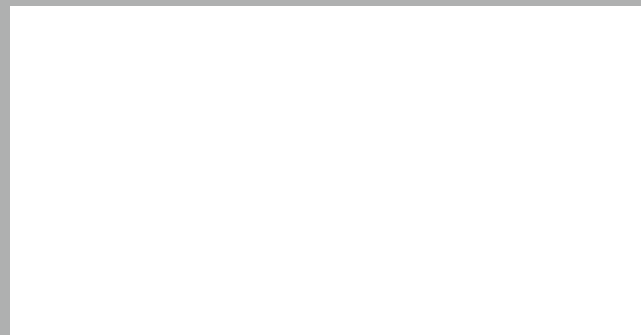

Eberspächer Climate Control Systems GmbH & Co. KG
Eberspächerstrasse 24
73730 Esslingen
GERMANY
Phone: +49 711 939 00
Fax: +49 711 939 -0634
info@eberspaecher.com
www.eberspaecher.com

